



HAL
open science

Enhancing the frequency stability of a NEMS oscillator with electrostatic and mechanical nonlinearities

Jérôme Juillard, Grégory Ardnt, Eric Colinet

► **To cite this version:**

Jérôme Juillard, Grégory Ardnt, Eric Colinet. Enhancing the frequency stability of a NEMS oscillator with electrostatic and mechanical nonlinearities. Euroensors'09, Procedia Chemistry, Sep 2009, Lausanne, Switzerland. pp.1415-1418. hal-00445428

HAL Id: hal-00445428

<https://centralesupelec.hal.science/hal-00445428>

Submitted on 8 Jan 2010

HAL is a multi-disciplinary open access archive for the deposit and dissemination of scientific research documents, whether they are published or not. The documents may come from teaching and research institutions in France or abroad, or from public or private research centers.

L'archive ouverte pluridisciplinaire **HAL**, est destinée au dépôt et à la diffusion de documents scientifiques de niveau recherche, publiés ou non, émanant des établissements d'enseignement et de recherche français ou étrangers, des laboratoires publics ou privés.

Enhancing the frequency stability of a NEMS oscillator with electrostatic and mechanical nonlinearities

J. Juillard¹, G. Arndt², E. Colinet²

¹SSE, SUPELEC, Gif-sur-Yvette, France

²CEA-LETI, MINATEC, Grenoble, France

Summary

We show how to achieve large-amplitude oscillation and good frequency stability in a nonlinear NEMS oscillator by using a softening nonlinearity to locally balance the hardening behaviour of the Duffing nonlinearity for a given motion amplitude. The case when the softening behaviour is obtained via electrostatic biasing is theoretically investigated, under parallel-plate assumptions, for a fully-capacitive pulse-actuated resonant structure. This is validated by simulated data, in the case of a resonant clamped-clamped beam.

Motivations and results

It is a challenge to achieve large-amplitude motion of NEMS oscillators without deteriorating their frequency stability [1]. On the one hand, achieving large oscillation amplitude leads to better SNR and, thus, simplifies the design of the electronic feedback loop. On the other hand, it results in a nonlinear frequency-amplitude relationship: for example, the frequency instability of a Duffing oscillator is proportional to its oscillation amplitude. In this paper, we show how to achieve large-amplitude oscillation *and* good frequency stability in a NEMS oscillator: the governing idea is to use a softening nonlinearity to locally balance the hardening behaviour of the Duffing nonlinearity for a given motion amplitude. We study the case when the softening behaviour is obtained via electrostatic biasing. The capacitive detection and actuation scheme is similar to the one in [2] (Fig. 1-2). The system is actuated with short voltage pulses, delivered when the position of the resonant element (typically a clamped-clamped beam) crosses zero: such a feedback scheme ensures that the system oscillates and is stable, even beyond the critical Duffing amplitude [3]. Considering the simpler case of parallel-plate actuation, we use describing function analysis to show that the self-oscillation pulsation ω of the closed-loop system is given by (1) (Fig. 3), where ω_0 is the natural pulsation of the resonant structure, A is the oscillation amplitude, normalized with respect to the gap and γ and δ are positive design-dependent coefficients respectively representing the strength of the Duffing hardening and that of the electrostatic softening. From (1), we establish that:

$$\frac{d\omega}{dA} = 0 \Leftrightarrow A = A_{opt} = \sqrt{1 - \left(\frac{\delta}{2\gamma}\right)^{2/5}}. \quad (2)$$

Thus, provided the structure is designed so that $\delta < 2\gamma$, there exists an optimal oscillation amplitude around which small perturbations on A have little impact on the value of ω . In order to ensure a large SNR, A_{opt} should be made as large as possible, but safely maintained below A_{pi} , for which electrostatic pull-in [5] occurs (Fig. 3-4). Similar analyses can be made in the case of flexible structures; although they are not tractable analytically, they lead to results that are qualitatively similar to (1-2) (Fig. 5). These theoretical results are compared with simulations, in the case of the resonant structure developed in the ANR-funded M&NEMS project (Fig. 6). This design approach remains qualitatively valid for several other actuation schemes (PLL, etc.).

Word count: 496

Corresponding author: Jérôme Juillard, Dept. SSE, Supélec, 3 rue Joliot-Curie, 91192 Gif-sur-Yvette Cedex, France, Tel: +33-1-69-85-14-08, Fax: +33-1-69-85-14-29, E-mail: jerome.juillard@supelec.fr.

References

- [1] Feng X.L., "Phase noise and frequency stability of very-high frequency silicon nanowire nanomechanical resonators", 14th International Conference on Solid-State Sensors, Actuators and Microsystems, pp. 327-30, 2007
- [2] Colinet E. *et al.*, "Actuation of resonant MEMS using short pulsed forces", Sensors and Actuators A, vol. 115 (2004), pp. 118-125
- [3] Juillard J. *et al.*, "From MEMS to NEMS: closed-loop actuation of resonant beams beyond the critical Duffing amplitude", 7th IEEE Conference on Sensors, 2008, pp 510-513
- [4] Kaajakari V. *et al.*, "Nonlinear limits for single-crystal silicon microresonators", J. MEMS, vol. 13 (2004), pp. 715-724
- [5] Elata D., "On the static and dynamic response of electrostatic actuators", Bulletin of the Polish Academy of Sciences, Technical Sciences, vol. 53, p 373-84

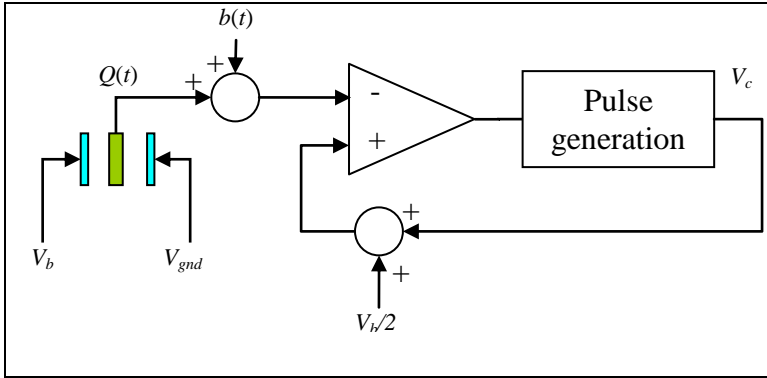

Fig. 1 - Principle of closed-loop pulse-actuation. The moving structure (in green) is the midpoint of a biased capacitive half-bridge. The amplifier's output voltage is proportional to the charge of the moving electrode. Short voltage pulses are fed back to the central electrode when the amplifier's output voltage crosses zero [2-3], so that oscillation builds up. Measurement noise $b(t)$ is responsible for frequency instability.

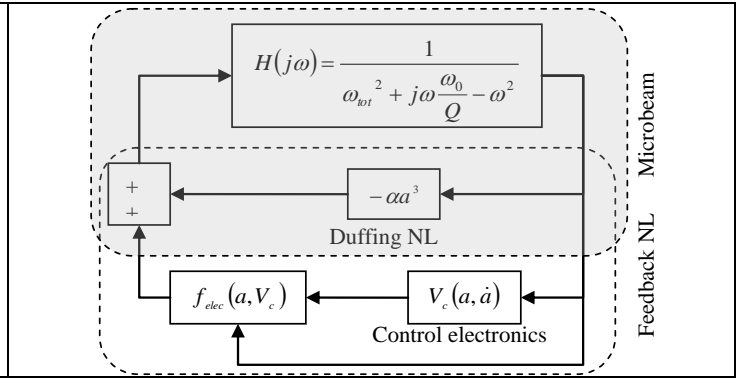

Fig. 2 - Equivalent block diagram of an electrostatically-actuated, stress-stiffened NEMS (shaded area) with its nonlinear feedback electronics and actuation scheme. The system may be looked at as a linear system with one complex feedback nonlinearity. Resonant NEMS usually have large quality factors, making it possible to study them with describing function analysis.

Parallel-plate structure

$$\omega = \omega_0 \sqrt{1 + \frac{3}{4} \gamma A^2 - \delta \frac{1}{(1 - A^2)^{3/2}}} \quad (1)$$

$$1 + \gamma A_{pi}^2 - \delta \frac{1}{(1 - A_{pi}^2)^2} = 0 \quad (3)$$

Clamped-clamped beam

$$\omega = \omega_0 \sqrt{1 + \frac{3}{4} \gamma A^2 - \delta \frac{4}{\pi} \frac{E(A^2) - (1 - A^2)K(A^2)}{A^2(1 - A^2)}} \quad (4)$$

$$1 + \gamma A_{pi}^2 - \delta \frac{1}{(1 - A_{pi}^2)^{3/2}} = 0 \quad (5)$$

Fig. 3 - For a pulse-actuated parallel-plate structure, it is possible to find analytical expressions for the optimal oscillation amplitude (2) and for the pull-in amplitude, which is governed by (3). (3) reduces to a third-degree polynomial in A_{pi}^2 . The pull-in amplitude corresponds to a maximum of the potential energy of the system. For a clamped-clamped beam, the expression of the closed-loop oscillation pulsation contains elliptic integrals (4): A_{opt} can only be determined numerically.

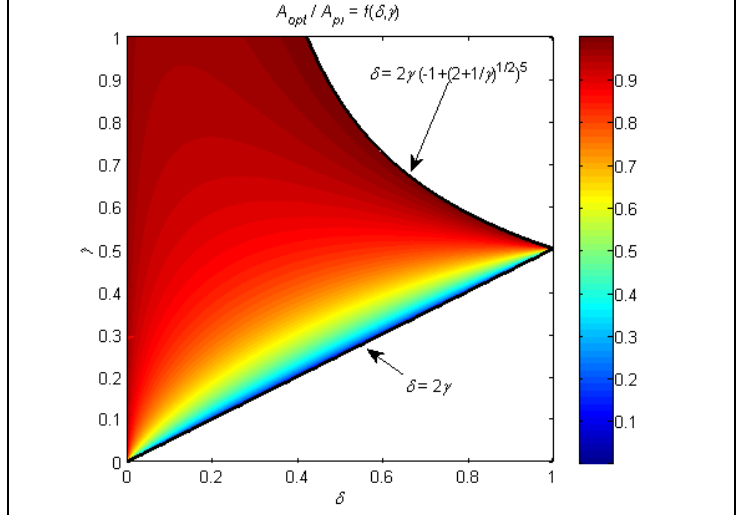

Fig. 4 - Map of A_{opt}/A_{pi} vs. δ and γ for a parallel-plate resonant structure. There exists no optimal amplitude below the lower boundary and $A_{opt} > A_{pi}$ above the upper boundary.

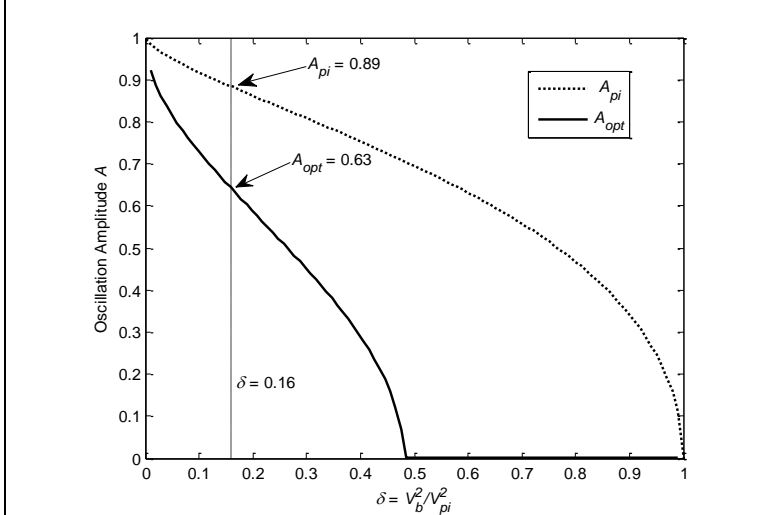

Fig. 5 - Plot of A_{opt} and A_{pi} vs. δ for the microbeam of the M&NEMS project ($\omega_0 = 2.2 \times 10^7 \text{ rad.s}^{-1}$, $\gamma = 0.72$, $V_{pi} = 30 \text{ V}$). The pull-in voltage V_{pi} is defined as the bias voltage for which the center position becomes unstable. $\delta = 0.16$ corresponds to $V_b = 12 \text{ V}$.

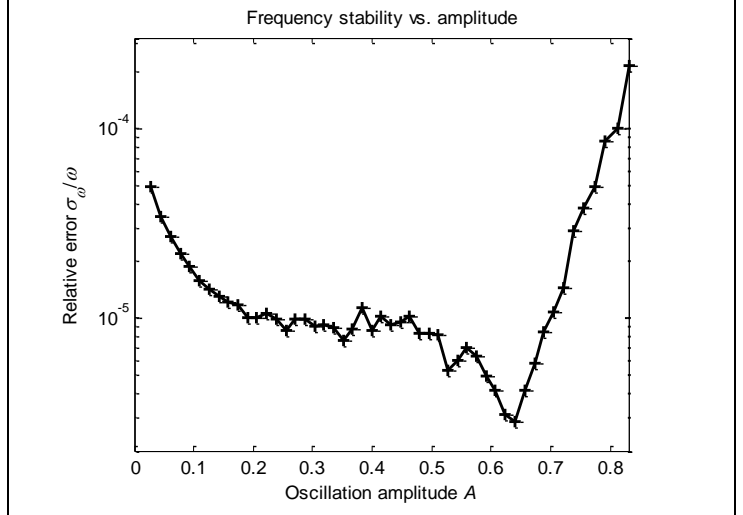

Fig. 6 - Simulated frequency stability of the M&NEMS structure under a 12V bias. The measurement noise is assumed white and has a uniform distribution. Each point of the curve corresponds to a nonlinear transient simulation of the closed-loop system, with a pulse amplitude varying between 10mV and 290mV. The relative error is defined as the ratio of the estimated standard deviation of the (amplitude-dependent) pulsation to its estimated mean. It is minimal close to the expected oscillation amplitude (Fig. 5). Note that, for small pulse amplitudes, the detected signal is drowned in the measurement noise, resulting in poor frequency stability.