



HAL
open science

Synthesis of Subband Hybrid Filter Banks ADCs with Finite Word-length Coefficients using Adaptive Equalization

Zhiguo Song, Caroline Lelandais-Perrault, Daniel Poulton, Philippe Benabes

► **To cite this version:**

Zhiguo Song, Caroline Lelandais-Perrault, Daniel Poulton, Philippe Benabes. Synthesis of Subband Hybrid Filter Banks ADCs with Finite Word-length Coefficients using Adaptive Equalization. 2010 IEEE International Symposium on Circuits and Systems (ISCAS 2010), May 2010, Paris, France. pp.577-580, 10.1109/ISCAS.2010.5537530 . hal-00519674

HAL Id: hal-00519674

<https://centralesupelec.hal.science/hal-00519674>

Submitted on 21 Sep 2010

HAL is a multi-disciplinary open access archive for the deposit and dissemination of scientific research documents, whether they are published or not. The documents may come from teaching and research institutions in France or abroad, or from public or private research centers.

L'archive ouverte pluridisciplinaire **HAL**, est destinée au dépôt et à la diffusion de documents scientifiques de niveau recherche, publiés ou non, émanant des établissements d'enseignement et de recherche français ou étrangers, des laboratoires publics ou privés.

Synthesis of Subband Hybrid Filter Banks ADCs with Finite Word-length Coefficients using Adaptive Equalization

Zhiguo Song, Caroline Lelandais-Perrault (*Member, IEEE*),
Daniel Poulton and Philippe Bénabes (*Member, IEEE*)
Department of Signal Processing and Electronic Systems
SUPELEC

91192 Gif sur Yvette, France

Email: `firstname.lastname@supelec.fr`

Abstract—Subband Hybrid Filter Banks (SHFB) ADCs are able to convert one or several narrow subbands among a given wideband signal. That provides an appropriate solution to “flexible spectrum” management for cognitive radio applications. In this paper, a SHFB ADC delivering a complex signal is considered. The optimal values of the digital coefficients are obtained thanks to an adaptive equalization method. The impact of digital coefficients quantization to the SHFB is studied. For a reconstruction quality target, the minimum quantization step is determined. This is validated in time and frequency domain with simulation results.

I. INTRODUCTION

Future cognitive radio systems should be able to adapt themselves to a multi-standard environment [1]. To achieve that, high performances ADCs are necessary. They should convert alternately a wideband signal with a low resolution for “sensing” purpose, and any narrow band signal with a higher resolution in a communication mode [2]. Hybrid Filter Banks (HFB) ADC seems to be a suitable solution for these requirements. Such a parallel architecture consists of an analog frequency decomposition (analysis bank), a conversion-stage (ADC bank) and a digital reconstruction (synthesis bank). From a given ADC sampling rate, an HFB ADC can enlarge the conversion bandwidth and perform bandpass sampling. Also, HFB can convert a narrow bandwidth with a higher resolution by reconfiguring its digital part. This can be achieved with a Subband HFB (SHFB) proposed in [3]. However, SHFBs are very sensitive to analog errors that mainly occur while manufacturing [3]. To solve this problem, an adaptive equalization method proposed in [4] finds the digital coefficients corresponding to the analog filter bank. Figure 1 shows the principle of the adaptive equalization method to synthesize a SHFB. A well chosen test signal is given at the input of the SHFB. The output of the SHFB is compared to the desired signal linked to the test signal. The error is used to correct the digital filter coefficients iteratively thanks to the Least Mean Square (LMS) algorithm [5]. When the error decreases so much that the reconstruction accuracy is achieved, the synthesis process is stopped. Practically, in an embedded system, the test signal and the desired signal samples may be stored in a memory.

In this paper, the SHFB ADC digital coefficients are Finite Word-Length (FWL) in complex form. The quantization

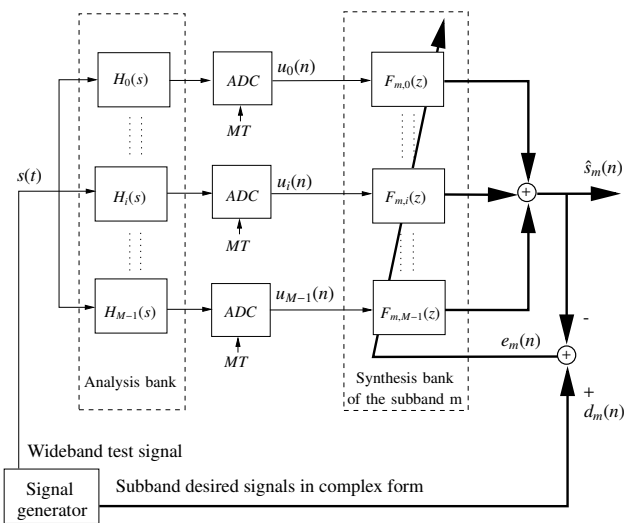

Fig. 1. Adaptive equalization for synthesizing of M -channel SHFB ADC, the subscripts m and i designate respectively the subband number and the channel number. $m, i \in [0, M - 1]$. T denotes the Nyquist sampling period of the input signal. The thick line designates the signal in complex form.

influences upon the subband reconstruction and the adaptive equalization are studied. By considering the test signal characteristics and a bank that contains ideal analog filters, a theoretical number of bits coding the digital coefficients may be determined function to the effective resolution of the SHFB.

In section II, the generations of the test signal $s(t)$ and the subband desired signal $d_m(n)$ in complex form are presented. Then, the synthesis method using adaptive equalization is justified theoretically for the SHFB ADC. In section III, the quantization influences of the digital coefficients are studied. The theoretical minimum number of quantization bits, which allows the SHFB achieve the required effective resolution is pointed out. In section IV, initializing the digital FWL coefficients to zero, an eight-channel SHFB ADC is simulated in both time and frequency domains. Based on the simulation results, the performances of the SHFB ADC are discussed.

II. ADAPTIVE EQUALIZATION FOR SYNTHESIZING A SHFB ADC

The main originality of the adaptive equalization method applied to the SHFB synthesis relies upon the choice of the

test and desired signals. The adaptive algorithm is the classical complex LMS algorithm [5].

A. Test signal $s(t)$ and desired signal $d_m(n)$

Let BW and T denote respectively the bandwidth and the Nyquist sampling period of $s(t)$. $2\pi\Omega_m$ designates the central frequency of the subband m , which bandwidth $BW_{sub} = \frac{2BW}{M}$. Let $G(j\Omega)$ designate the frequency response of a lowpass filter (LF), which bandwidth is equal to BW_{sub} . In order to avoid the additional interferences generated by the frequencies apart the passband, the LF's selectivity should be high [6]. After being modulated by $e^{j\Omega_m}$, the LF is transferred to complex bandpass filters (CBF). As shown in Figure 2, a pseudo zero-mean white noise signal filtered by the CBFs, the subband signal $S_m(j\Omega)$ is obtained. Then, the test signal is achieved by $\sum_{m=0}^{M-1} S_m(j\Omega)$, which variance is noted by σ_s^2 . Let denote $\sigma_{s_m}^2$ the variance of subband signal, since $s(t)$ consists M subband signals, we have

$$\sigma_{s_m}^2 = \frac{\sigma_s^2}{M} \quad (1)$$

Thanks to the complex bandpass sampling, $S_m(j\Omega)$ is down-converted directly to obtain the desired signal $d_m(n)$ with aliasing free.

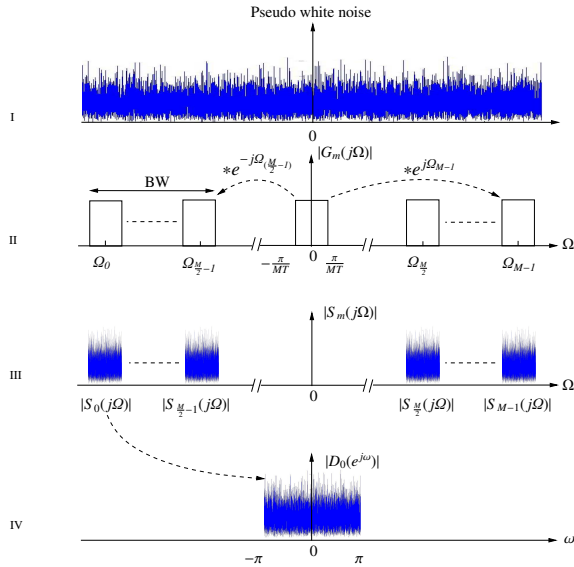

Fig. 2. Generations of the test signal $s(t)$ and $d_m(n)$. The spectra of : (I) a pseudo white noise, (II) transferring the lowpass filter to the bandpass filters, (III) the test signal $s(t)$ and (IV) the desired signal of the subband 0: $d_0(n)$.

B. Adaptive synthesis of the complex SHFB ADC

The digital reconstruction of the subband m through the SHFB ADC can be presented in frequency-domain by

$$\hat{S}_m(e^{j\omega}) = \sum_{p=-(M-1)}^{M-1} S\left(j\left(\Omega - \frac{2\pi p}{MT}\right)\right) T_{m,p}(e^{j\omega}) \quad (2)$$

with the reconstruction function $T_{m,p}$ that is defined by

$$T_{m,p}(e^{j\omega}) = \sum_{i=0}^{M-1} H_i\left(j\left(\Omega - \frac{2\pi p}{MT}\right)\right) F_{m,i}(e^{j\omega}) \quad (3)$$

where H_i denotes the transfer function of analysis filter in the channel i , $F_{m,i}$ designates the transfer function of the synthesis filter in subband m channel i . Ω means the pulsation and its normalization defined by $\omega = \Omega T$. For the purpose of the SHFB's perfect reconstruction, the sum of the aliasing terms $T_{m,p \neq 0}$ should be 0, and the distortion term $T_{m,p=0}$ must satisfy [3]

$$T_{m,0}(e^{j\omega}) = \sum_{i=0}^{M-1} H_i\left(j\frac{\omega}{T}\right) F_{m,i}(e^{j\omega}) = e^{-j\omega\rho} \quad \rho \in \mathbb{R}_*^+ \quad (4)$$

Let $\mathbf{u}(n)$ designate all the inputs of the synthesis bank, we have

$$\mathbf{u}(n) = [\mathbf{u}_0(n), \dots, \mathbf{u}_i(n), \dots, \mathbf{u}_{M-1}(n)]^T, \quad (5)$$

where $\mathbf{u}_i(n)$ denotes the inputs of the channel i , \mathbf{v}^T means the transpose of the vector \mathbf{v} . L -tap finite impulse response (FIR) filters are used in the synthesis bank, so, $\mathbf{u}_i(n) = [u_i(n), \dots, u_i(n-l), \dots, u_i(n-l+1)]$, $l \in [0, L-1]$.

The complex synthesis filters coefficients in the subband m channel i may denoted by the vector $\tilde{\mathbf{f}}_{m,i} = [\tilde{f}_{m,i}(0), \dots, \tilde{f}_{m,i}(L), \dots, \tilde{f}_{m,i}(L-1)]$. During the synthesis process, the coefficient $\tilde{f}_{m,i}(l)$ is adjusted to minimize the reconstruction error iteratively. Therefore, the vector that contains all of the synthesis coefficients of the subband m may be given by

$$\tilde{\mathbf{f}}_m = [\tilde{\mathbf{f}}_{m,0}, \dots, \tilde{\mathbf{f}}_{m,i}, \dots, \tilde{\mathbf{f}}_{m,M-1}] \quad (6)$$

Hence, the SHFB ADC's estimated output $\hat{s}_m(n)$ and the reconstruction error $e_m(n)$ can be represented as follows

$$\hat{s}_m(n) = \tilde{\mathbf{f}}_m^* \mathbf{u}(n) \quad (7)$$

$$e_m(n) = d_m(n) - \hat{s}_m(n) \quad (8)$$

where “*” denotes the operator of conjugation. We define $\mathbf{J} = \mathbb{E}[e_m(n)^2]$ the cost function for the reconstruction of subband m , where \mathbb{E} means the operator of expectation. According to [4], the optimal synthesis coefficients can be approximated by applying the complex LMS algorithm [5]. The iterative adjustments of the coefficients in complex form are given as follows

$$\tilde{\mathbf{f}}_m^I(n+1) = \tilde{\mathbf{f}}_m^I(n) + \mu e_m^I(n) \mathbf{u}(n) \quad (9)$$

$$\tilde{\mathbf{f}}_m^Q(n+1) = \tilde{\mathbf{f}}_m^Q(n) + \mu e_m^Q(n) \mathbf{u}(n) \quad (10)$$

where μ is named step-size, “ $\mu e_m(n) \mathbf{u}(n)$ ” are considered as correction term. The superscripts I and Q designate “in-phase” and “quadrature” components, that is real and imaginary parts of the complex number respectively. The implementation of (9) and (10) in the synthesis bank is presented in Figure 3. The condition of stability of the implemented complex LMS [5] in the SHFB ADC context can be defined by [4]

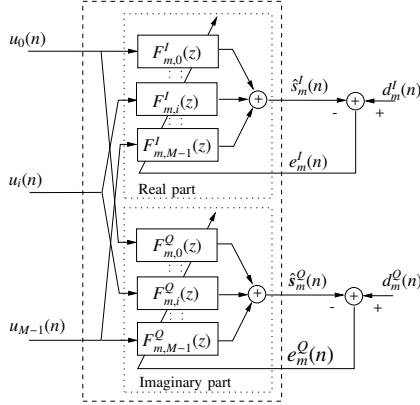

Fig. 3. Synthesis of the complex SHFB ADC by using the complex LMS algorithm.

$$0 < \mu < \frac{1}{MLE[u_i^2(n)]} = \frac{1}{ML\sigma_u^2} \quad (11)$$

where $E[u_i^2(n)]$ denotes the expectation of the power spectral density of the synthesis bank inputs. Since the test signal is supposed to be zero-mean, and so does $\mathbf{u}(n)$. Thus, we have $\sigma_u^2 = E[u_i^2(n)]$. Furthermore, $s(t)$ is decomposed into M channels by the analog filters which are assumed without overlap, the relationship between σ_u^2 and σ_s^2 can be represented by

$$\sigma_u^2 = \frac{\sigma_s^2}{M} \quad (12)$$

Let substitute (12) in (11), we have

$$\mu_{max} < \frac{1}{L\sigma_s^2} \quad (13)$$

III. INFLUENCES OF SYNTHESIS COEFFICIENT QUANTIZATION

A. Degradation of the SHFB ADC's reconstruction accuracy

Let define the following model to represent the complex synthesis coefficients in the subband m

$$\tilde{\mathbf{f}}_m = \mathbf{Q}[\hat{\mathbf{f}}_m] + \tilde{\epsilon} \quad (14)$$

where the vectors $\mathbf{Q}[\hat{\mathbf{f}}_m]$ and $\tilde{\epsilon}$ denote respectively the FWL FIR coefficients and quantization errors, $\mathbf{Q}[\cdot]$ means quantization operator. Let introduce (14) into (7), then substitute (7) into (8), we have

$$e_m(n) = d_m(n) - \mathbf{Q}[\hat{\mathbf{f}}_m^*] \mathbf{u}(n) - \tilde{\epsilon} \mathbf{u}(n) \quad (15)$$

Hence, the degradation of the reconstruction accuracy due to quantization errors can be presented by

$$\Delta_{e_m(n)} = \tilde{\epsilon} \mathbf{u}(n) = \sum_{i=0}^{M-1} \sum_{l=0}^{L-1} \tilde{\epsilon}_i(l) u_i(n-l) \quad (16)$$

where $\tilde{\epsilon}_i$ and u_i are assumed to be independent random zero-mean values, so, the variance of $\Delta_{e_m(n)}$ can be given by

$$\sigma_{\Delta_{e_m}}^2 = ML\sigma_{\tilde{\epsilon}}^2\sigma_u^2 \quad (17)$$

In order to simplify the demonstration thereafter, the analysis and synthesis filters are supposed to be ideal bandpass filters. Assuming that the gain of $H_i(s)$ is equal to 1 [7], the gain of $F_{m,i}(z)$ should be 1 according to (4). Let B_m denote the number of bits coding the digital coefficients. Since the maximum absolute value of the synthesis coefficients is 1, the quantization errors can be given by

$$\sigma_{\tilde{\epsilon}}^2 = \frac{\left(\frac{1}{2^{B_m-1}}\right)^2}{12} = \frac{1}{3 \times 2^{2B_m}} \quad (18)$$

Let introduce (12) and (18) into (17), and according to (1), we have

$$\sigma_{\Delta_{e_m}}^2 = \frac{L\sigma_s^2}{3 \times 2^{2B_m}} = \frac{ML\sigma_{s_m}^2}{3 \times 2^{2B_m}} \quad (19)$$

Usually, the quantization noise is measured in term of signal-to-noise ratio (SNR) which is defined as following for the subband m

$$SNR_m = 10 \log_{10} \left[\frac{\sigma_{s_m}^2}{\sigma_{e_m}^2} \right] \approx 6N_m \quad (20)$$

where N_m designates the effective resolution of the subband m in bit. For the reconstruction of SHFB ADC with an expected resolution N_m , the following relationship must be satisfied

$$\sigma_{e_m}^2 \approx \frac{\sigma_{s_m}^2}{10^{0.6N_m}} \gg \sigma_{\Delta_{e_m}}^2 \quad (21)$$

According to (19) and (21), the estimated quantization number of bits \hat{B}_m coding the synthesis coefficients should be

$$\hat{B}_m \gg 0.5 \log_2 \left[\frac{ML10^{0.6N_m}}{3} \right] \quad (22)$$

B. Effect to the adaptive equalization

Due to quantization errors, the adjustments of the coefficients can continue in the condition of the LMS correction term is bigger than half of the quantization interval [8]. This may be presented by

$$|\mu e_m(n) u_m(n-l)| > \frac{1}{2^{B_m}} \quad (23)$$

The condition above can be approximated by the root mean square value of their magnitudes. That is

$$\mu \sigma_{e_m} \sigma_u > \frac{1}{2^{B_m}} \quad (24)$$

Let substitute σ_u by (12) and μ by (13) into (24). Then, according to (1) and (20), we obtain the estimated minimum value of \hat{B}_m

$$\hat{B}_m^{min} > 3.33 [\log_{10}(ML) + 0.3N_m] \quad (25)$$

\hat{B}_m^{min} allows the LMS algorithm to continue the adjustments of $\mathbf{Q}[\hat{\mathbf{f}}_m]$ to approach their optimal values $\mathbf{Q}[\hat{\mathbf{f}}_m^{opt}]$. Hence, the SHFB's reconstruction accuracy can be satisfied with $\mathbf{Q}[\hat{\mathbf{f}}_m^{opt}]$.

IV. SIMULATION RESULTS

A. Conditions of simulation

Considering the wideband signal to convert is in the frequency band [0.85 1.25]GHz. The analog signal is split into a bank of analog bandpass filters which consists in eight pure Gm-LC resonators [2]. Their central frequencies and quality factors are respectively $2\pi\Omega_i$ and Q_i . The transfer function of the analysis filter of each channel is given by

$$\mathbf{H}_i(s) = \frac{\frac{\Omega_i}{Q_i} s}{s^2 + \frac{\Omega_i}{Q_i} s + \Omega_i^2} \quad (26)$$

A pseudo random sequence is used as a source signal, the test signal and desired signal are generated by following the process described in the section II.A. In order to reduce the aliasing terms, it is efficient to allocate a small part of frequency borders (low and high frequencies) at the spectrum as guard band (GB) [4], which is equal to 7% of the bandwidth in this paper. The adaptive synthesis process is performed upon the subband 0. The reconstruction accuracy is defined by SNR_0 that is expected to be 82 dB, i.e. an effective resolution of $N_0=14$. That should satisfy the requirements of communication mode like GSM [9]. According to (22) and (25), the estimated $\hat{B}_0^{min} > 24$ bit, then \hat{B}_0^{min} is equal to 25 bit.

B. Simulation results of synthesis in time domain

The digital coefficients in complex form are initialized to zero. The synthesis process of the SHFB ADC is simulated in the time-domain with Matlab using C MEX-functions. With different B_0 values, several simulations are performed and the results are shown in Figure 4. To achieve the required resolution of 14 bit, the experimental minimum quantization number of bits, noted by B_0^{min} , is equal to 28 bit. B_0^{min} exceeds here its theoretical value of 3 bit. Indeed, in the theoretical proof in section III, the analog filters have been assumed ideal with uniform frequency response in the appreciate subband. These hypotheses can be satisfied so hardly that they cause a degradation compared to the theoretical result. With $B_0=28$ bit, in the end of the 800th iteration, the synthesis process meets the required resolution of 14 bit. And from then, the LMS cannot continue the adjustments of the coefficients. Thus, we can stop the process. The saved coefficients can be considered having their optimal quantized values noted by $\mathbf{Q}[\mathbf{f}_0^{opt}]$.

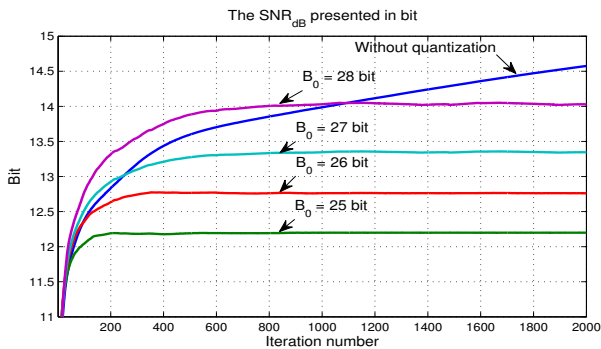

Fig. 4. Influence of digital coefficient quantization to the SHFB ADC's reconstruction accuracy and adaptive equalization.

C. Validation in frequency domain

Fixing $\mathbf{Q}[\mathbf{f}_0^{opt}]$ and introducing their frequency responses $F(e^{j\omega})$ into the reconstruction function (3), the distortion term and the sum of the aliasing terms can be calculated in decibel (Figure 5). Their mean values are $\mathbb{E}[(T_{0,0})_{dB}] = 1 \times 10^{-5}$ dB and $\mathbb{E}[\sum(T_{0,p \neq 0})_{dB}] = -85$ dB respectively. Hence, the performance of the SHFB can be presented by the Mean Distortion-to-Aliasing Ratio (MDAR) [4]. We have $MDAR_{dB} = \mathbb{E}[(T_{0,0})_{dB}] - \mathbb{E}[\sum(T_{0,p \neq 0})_{dB}] = 85$ dB, i.e. a resolution of 14.1 bit. This presents an accordance with the simulation results in time domain.

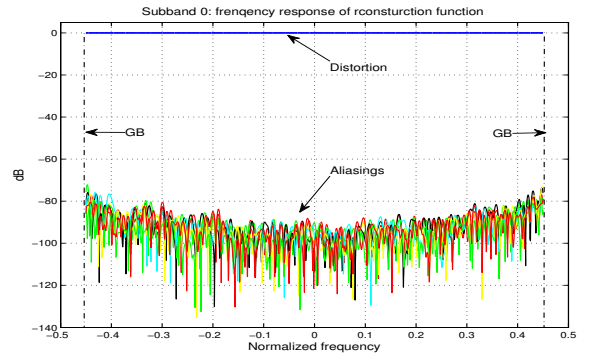

Fig. 5. Frequency response of the SHFB ADC with $\mathbf{Q}[\mathbf{f}_0^{opt}]$, where $B_0 = 28$ bit.

V. CONCLUSION

In this paper, the influence of digital coefficient quantization to the SHFB's reconstruction is studied. In order to guarantee the subband reconstruction accuracy by using the adaptive equalization, the minimum number of bits coding coefficient is theoretically pointed out. Due to the hypotheses are not be satisfied practically, it needs supplemental 3 bits over the theoretical value to obtain an effective resolution of 14 bit on the SHFB's output. Thanks to the simplicity of the LMS algorithm, the adaptive synthesis process makes the SHFB realistic for cognitive radio applications, such as "flexible spectrum" management.

REFERENCES

- [1] B. Fette(Editor), "Cognitive radio technology" Newnes Elsevier, 2006.
- [2] C. Lelandais-Perrault, T. Petrescu, D. Poulton, P. Duhamel, J. Oksman, "Wide-band, band pass and versatile Hybrid Filter Bank A/D, conversion for software radio", in *IEEE TCAS-I (Transactions Circuits and Systems I)*, vol. 56, No. 8, August 2009.
- [3] D. Asemami, J. Oksman and P. Duhamel "Subband architecture for Hybrid Filter Bank A/D converters", in *IEEE Journal on selected Topics in Signal Processing*, Vol.2, No. 2, pp.191-201, April 2008.
- [4] Z. Song, C. Lelandais-Perrault, P. Benabes, "Synthesis of complex subband hybrid filter banks A/D converters using adaptive filters", in *The 16th IEEE International Conference on Electronics, Circuits, and Systems*, December 2009, accepted.
- [5] S. Haykin(Editor), "Adaptive Filter Theory" Prentice Hall, 2002.
- [6] D. Poulton, "Anti-aliasing Filter in Hybrid Filter Banks", in *IEEE Second International Symposium on Communications, Control and Signal Processing*, March 2006.
- [7] P. Löwenborg, and H. Johansson, "Quantization noise in filter bank analog-to-digital converters", in *IEEE International Symposium on Circuits and Systems*, May 2001.
- [8] Z. Zhang, G. Schmer "Analysis of Filter Coefficient Precision on LMS Algorithm-Performance for G.165/G.168 Echo Cancellation", in *Application Report, Texas Instruments*, February 2000.
- [9] C. Lelandais-Perrault, Z. Song, D. Poulton, P. Benabes, "Hybrid Filter Bank A/D conversion systems applied to future telecommunication scenarios", *Joint IEEE-NEWCAS and TAISA Conference*, June 2009.