



**HAL**  
open science

## **New non-uniform transmission and ADPCM coding system for improving both signal to noise ratio and bit rate**

Elisabeth Lahalle, Gilles Fleury, Rawad Zgheib

► **To cite this version:**

Elisabeth Lahalle, Gilles Fleury, Rawad Zgheib. New non-uniform transmission and ADPCM coding system for improving both signal to noise ratio and bit rate. *IEEE Signal Processing Letters*, 2011, 18 (3), pp.149-152. 10.1109/LSP.2010.2102016 . hal-00573552

**HAL Id: hal-00573552**

**<https://centralesupelec.hal.science/hal-00573552v1>**

Submitted on 4 Mar 2011

**HAL** is a multi-disciplinary open access archive for the deposit and dissemination of scientific research documents, whether they are published or not. The documents may come from teaching and research institutions in France or abroad, or from public or private research centers.

L'archive ouverte pluridisciplinaire **HAL**, est destinée au dépôt et à la diffusion de documents scientifiques de niveau recherche, publiés ou non, émanant des établissements d'enseignement et de recherche français ou étrangers, des laboratoires publics ou privés.

# New non-uniform transmission and ADPCM coding system for improving both signal to noise ratio and bit rate

Elisabeth Lahalle\*, Gilles Fleury, Rawad Zgheib

**Abstract**—Here we address the problem of adaptive digital-transmission systems. New systems based on a nonuniform transmission (NUT) principle are proposed, utilizing a recently proposed algorithm for adaptive identification and reconstruction of AR processes subject to missing data. We propose a new adaptive sampling (nonuniform transmission) method combined with the adaptive reconstruction algorithm. A new NUT-ADPCM coding-decoding system is designed. The proposed system is demonstrated for audio-signal compression and compared to the ADPCM G.726 standard. The new system yields improvements in both signal-to-noise ratio and average bit rate.

**Index Terms**—Adaptive transmission, adaptive reconstruction, audio-signal compression.

## I. INTRODUCTION

IN the design of digital transmission systems, it is important to find a good tradeoff between a low bit rate and a high signal-to-quantization-noise ratio [7], [9]. In a previous study [5], a new concept for the design of digital coding systems was introduced, based on nonuniform transmission of signal samples. The idea is to avoid transmitting a sample if it can be efficiently predicted. The use of the nonuniform transmission principle in an ADPCM coding system was first suggested in [6]. An LMS-like algorithm [4] was suggested for the prediction of samples that were not transmitted. However, this algorithm converges toward biased estimations of the model parameters and does not use an optimal predictor in the least-mean-squares sense [10].

Recently, we proposed two new adaptive algorithms for the identification and reconstruction of nonstationary AR processes subject to missing data using a Kalman filter for the prediction. The first algorithm is based on a pseudolinear RLS algorithm for the identification [11], and the second [12] is based on a lattice filter structure, thus guaranteeing stability and robustness [2], [3]. Both algorithms are fast and offer an optimal reconstruction error in the least-mean-squares sense. They showed good performance in terms of quadratic reconstruction error when applied to speech-signal reconstruction with a high probability of missing samples. Indeed, nonstationary AR processes can model a large number of signals in practical situations such as speech signals [7], [3]. We here propose to use these algorithms in a nonuniform transmission (NUT) system, previously introduced in [5], to

improve its performance. We then combine them with adaptive reconstruction algorithms to design a new NUT-ADPCM coding-decoding system.

In the following, we begin by recalling the nonuniform transmission idea introduced in [5], then the adaptive algorithm for the reconstruction of AR processes with missing observations [11]. The performance of NUT transmission systems using [4] and [11] identification algorithms are compared. Finally, a new NUT-ADPCM system is designed. It is compared in the last section to the ADPCM [1] coding system through simulations of speech signals.

### A. NUT Coding

1) *Adaptive sampling*: In a simplified digital-transmission system, assuming that the channel is perfect, the reconstruction error is equal to the quantization error. Mirsaidi et al. [5] proposed a novel nonuniform transmission system that reduced quantization error by using a parametric signal-modeling approach for the prediction. In the receiver, a sample at time  $n$  is predicted using the estimated model parameters at time  $n-1$  and the available quantized samples. The key idea of the system they proposed is that at time  $n$  an efficient prediction may provide a smaller error than a quantization. In this case, it is better to replace the transmitted quantized sample with its prediction in the receiver. Thus, using an efficient prediction method for signals subject to missing samples, the number of transmitted samples is considerably reduced and the reconstruction performance is also improved.

2) *Kalman Pseudo-linear RLS Algorithm*: Let  $\{x_n\}$  be an AR process of order  $L$  with parameters  $\{a_k\}$ , and  $\{\epsilon_n\}$  the corresponding innovation process of variance  $\sigma_\epsilon^2$ . The loss process is modeled by an i.i.d. binary random variable  $\{c_n\}$ , where  $c_n = 1$  if  $x_n$  is available; otherwise,  $c_n = 0$ . Let  $\{z_n\}$  be the reconstruction of the process  $\{x_n\}$ . If  $x_n$  is available  $z_n = x_n$ ; otherwise,  $z_n = \hat{x}_n$ , the prediction of  $x_n$ . To identify the AR process subject to missing data in real time, we use the pseudolinear RLS algorithm [8]. In the case of missing observations, the regression vector  $\Psi_n = [x_{n-1} \dots x_{n-L}]^\top$  cannot be constructed with only available data. Missing data are replaced by their predictions, i.e.,  $\hat{\Psi}_n = [z_{n-1} \dots z_{n-L}]^\top$ . Thus,  $\hat{\Psi}_n$  depends on the available parameters. We show [11] that the least-squares estimate of the parameters is unbiased if the predictor used is optimal in the least-mean-squares sense. A Kalman filter is used for recursive optimal prediction. Let  $\mathbf{x}_n = [x_n \dots x_{n-L+1}]^\top$  be the state vector. The predicted

E. Lahalle, G. Fleury and R. Zgheib are with E3S - SUPELEC Systems Sciences / Dept. of Signal Processing and Electronic Systems, Gif-sur-Yvette, France e-mail: (firstname.lastname@supelec.fr), tel: +33(0)1 69 85 14 27, fax:+33(0)1 69 85 14 29.

and filtered estimates are denoted by  $\hat{\mathbf{x}}_{n+1|n}$  and  $\hat{\mathbf{x}}_{n+1|n+1}$ , respectively.  $P_{n+1|n}$  and  $P_{n+1|n+1}$  are, respectively, the prior and posterior prediction-error covariance matrices.  $K_{n+1}$  is the Kalman filter gain. The Kalman pseudolinear RLS algorithm is summarized, at time  $n+1$ , as follows :

$$A_{n+1} = \left[ \begin{array}{ccc|c} \hat{a}_{n,1} & \dots & \dots & \hat{a}_{n,L} \\ 1 & & & 0 \\ & \ddots & & \vdots \\ 0 & & 1 & 0 \end{array} \right] \quad (1)$$

$$P_{n+1|n} = AP_{n|n}A^\top + R_\epsilon, \quad (2)$$

$$\hat{\mathbf{x}}_{n+1|n} = A\hat{\mathbf{x}}_{n|n}, \quad (3)$$

$$\hat{\Psi}_n = \hat{\mathbf{x}}_{n|n}, \quad (4)$$

If  $x_{n+1}$  is available, i.e.  $c_{n+1} = 1$ , the predicted state vector  $\hat{\mathbf{x}}_{n+1|n}$  is filtered by the Kalman filter ((5),(6),(7)) and the AR parameters are updated using the RLS-like algorithm ((8),(9),(10)):

$$K_{n+1} = P_{n+1|n}\mathbf{c}_{n+1}(\mathbf{c}_{n+1}^\top P_{n+1|n}\mathbf{c}_{n+1})^{-1}, \quad (5)$$

$$P_{n+1|n+1} = (I_d - K_{n+1}\mathbf{c}_{n+1}^\top)P_{n+1|n}, \quad (6)$$

$$\hat{\mathbf{x}}_{n+1|n+1} = \hat{\mathbf{x}}_{n+1|n} + K_{n+1}(y_{n+1} - \mathbf{c}_{n+1}^\top \hat{\mathbf{x}}_{n+1|n}), \quad (7)$$

$$\gamma_{n+1} = \frac{c_n G_n \hat{\Psi}_{n+1}}{\lambda + \hat{\Psi}_{n+1}^\top G_n \hat{\Psi}_{n+1}}, \quad (8)$$

$$\hat{\mathbf{a}}_{n+1} = \hat{\mathbf{a}}_n + \gamma_n(y_{n+1} - \mathbf{c}_{n+1}^\top \hat{\mathbf{x}}_{n+1|n}), \quad (9)$$

$$G_{n+1} = \frac{1}{\lambda}(I_d - \gamma_{n+1}\hat{\Psi}_{n+1}^\top)G_n \quad (10)$$

If  $x_{n+1}$  is missing, i.e.  $c_{n+1} = 0$ , the predicted state vector is not filtered by the Kalman filter and the AR parameters are not updated using the RLS-like algorithm :

$$K_{n+1} = 0, \quad (11)$$

$$P_{n+1|n+1} = P_{n+1|n}, \quad (12)$$

$$\hat{\mathbf{x}}_{n+1|n+1} = \hat{\mathbf{x}}_{n+1|n}, \quad (13)$$

$$\gamma_{n+1} = 0, \quad (14)$$

$$\hat{\mathbf{a}}_{n+1} = \hat{\mathbf{a}}_n, \quad (15)$$

$$G_{n+1} = \frac{1}{\lambda}G_n \quad (16)$$

3) *Comparison*: In this section, the periodic transmission system, the nonuniform transmission system using the LMS-like algorithm proposed in [4], and the Kalman pseudolinear RLS Algorithm are compared; the methods are referred to hereafter as Methods 1, 2 and 3, respectively. The test signal used was "Mary had a little lamb, its fleece was white as snow" sampled at  $F_s = 8\text{kHz}$ . The forgetting factor used in the pseudolinear RLS algorithm [11] is  $\lambda = 0.999$  and the step-size used in the LMS-like algorithm [4] is  $\mu = 7.10^{-5}$ . In both parametric methods, the speech signal is modeled by an AR process of order 10. The three methods are evaluated in terms of mean bit rate and the signal-to-reconstruction error ratio given by:  $(SNR) = 10\log_{10} \left( \frac{\sum_{i=1}^N x_i^2}{\sum_{i=1}^N (x_i - \hat{x}_i)^2} \right)$ . In the case of a transmitted sample, the reconstruction error is the same as the quantization error; in the case of a missing sample, it is the same as the prediction error. For the periodic transmission system, the bit rate is given by  $r = BF_s$ , where  $B$  is the number of bits per sample. For other two methods, a one-bit flag is transmitted for each nontransmitted sample. We consider the average bit rate, given by  $r = (TB + 1)F_s$ , where  $T$  stands for the proportion of samples transmitted.

TABLE I  
COMPARISON OF THE THREE METHODS

Method	B	$T$	$(SNR)_{dB}$	Bit rate
1	4	1	22.05	32
1	5	1	27.27	40
2	5	0.88	27.34	43.48
3	5	0.60	28.72	31.85
ADPCM	4	1	23.5	32

For comparison purposes, Table I shows the results of the three methods. They are compared with respect to the signal-to-noise ratio (SNR) and the bit-rate performance of the G.726 ADPCM codec at 32 kbits. For almost the same SNR, Method 2 shows a higher average bit rate than for periodic transmission with  $B = 5$ , which is of course due to the one-bit flag. In contrast, Method 3, using an optimal predictor [11], outperforms all other methods in both SNR and average bit rate. Consequently, a new nonuniform transmission ADPCM coding system using an optimal predictor [11] [12] is proposed below.

### B. NUT-ADPCM Coding

The ADPCM codec, defined by the ITU-T Recommendations G.726 [1], is based on the differential coding principle (DPCM). Because the difference between the signal and its prediction has a lower variance than the original samples, it can be accurately quantized with fewer bits than the original samples. The performance of the codec is aided by using adaptive prediction and quantization, so that the predictor and difference quantizer adapt to the changing characteristics of the signal being coded. The adaptive predictor used is based on an ARMA(2,6) model of the signal.

1) *system design*: When the prediction method used is efficient, the prediction error of some samples might be of a magnitude less than the minimal quantization step provided by the adaptive quantizer. We propose avoiding transmitting

the quantized prediction errors in that case and so expect to reduce the number of transmitted bits without sacrificing reconstruction quality. Therefore, the adaptive predictor used in the transmission and reception must solve the problem of the reconstruction of signals with missing samples. In addition, the transmission of a one-bit flag to indicate the transmission mode is required. The proposed system differs from the ADPCM codec mainly in the adaptive predictor used. Additionally, it contains a transmission-decision element for the quantized prediction error and for the one-bit flag.

*Adaptive predictor:* We then use the Kalman Recursive Least-Squares Lattice algorithm (KRLSL) [12] algorithm as an adaptive predictor in the NUT-ADPCM coding system instead of the Kalman RLS [11] to ensure the stability of the system. The signal is modeled by a nonstationary AR( $L$ ) process of order 10 instead of an ARMA(2,6). Recall here that the KRLSL algorithm is based on an adaptive Burg algorithm for the identification of the AR parameters, thus guaranteeing at each time point the stability of the identified filter [12].

Additionally, the KRLSL algorithm uses a Kalman filter for the prediction of the samples. When a sample is available, the state, consisting of the last  $L$  samples, is updated by the Kalman filter proportionally to the prediction error of the sample [12]. However, in the case of NUT-coding systems, the receiver has only quantized versions of the prediction errors. Therefore, even if the true prediction error of a sample is known at the transmitter, the quantized prediction error is used with the Kalman filter to update the state. This reproduces the same sample prediction as is done in the receiver. Hence, when a quantized prediction error is received, the sample reconstruction is computed as in equation  $\hat{x}_{n|n} = \hat{x}_{n|n-1} + e_{n,P}^Q$ . The sample thus reconstructed is used to initialize the lattice-identification algorithm ((17)).

In the KRLSL algorithm, the recursive equations of the RLS algorithm ((17),(18),(19),(20),(21),(22),(23)) are used instead of the equations of the RLS algorithm ((8),(9),(10)) at each available sample,  $x_{n+1}$ . They are used to estimate the reflection coefficients  $\hat{k}_t^{(l)}$  at each time  $t$  since the last available sample. The AR parameters, at time  $n + 1$ , are then deduced from the reflection coefficients  $\hat{k}_{n+1}^{(l)}$  using the Durbin-Levinson recursions.

$$\hat{f}_t^{(0)} = \hat{b}_t^{(0)} = \hat{x}_{t|n+1}, \quad (17)$$

$$\hat{k}_t^{(0)} = 1, \quad (18)$$

$$\hat{C}_t^{(l)} = \lambda \hat{C}_{t-1}^{(l)} - 2\hat{f}_t^{(l-1)}\hat{b}_{t-1}^{(l-1)}, \quad (19)$$

$$\hat{D}_t^{(l)} = \lambda \hat{D}_{t-1}^{(l)} - \hat{f}_t^{(l-1)2}\hat{b}_{t-1}^{(l-1)2}, \quad (20)$$

$$\hat{k}_t^{(l)} = -\frac{\hat{C}_t^{(l)}}{\hat{D}_t^{(l)}}, \quad (21)$$

$$\hat{f}_t^{(l)} = \hat{f}_t^{(l-1)} - \hat{k}_t^{(l)}\hat{b}_{t-1}^{(l-1)}, \quad (22)$$

$$\hat{b}_t^{(l)} = \hat{b}_t^{(l-1)} - \hat{k}_t^{(l)}\hat{f}_{t-1}^{(l-1)} \quad (23)$$

*Transmission decision:* Once the sample is predicted via the Kalman filter, the prediction error is quantized using the same adaptive quantizer as described in the recommendations of the G.726 specifications [1]. If the sample is perfectly predicted (i.e., the prediction error is quantized to zero), the code corresponding to the quantized prediction error is not transmitted. A one-bit flag must also be transmitted to the receiver. In the transmitter, the adaptive predictor must be informed about the transmission decision of the sample code to execute the appropriate steps, which are also executed in the receiver. In this scheme, to reduce the number of bits transmitted, the number of codes transmitted should compensate for the extra bit flag. Thus, let  $N$  be the size of a signal coded using an ADPCM codec at  $B$  bits. The total number of bits transmitted is then equal to  $B_{ADPCM} = NB$  bits. The nonuniform transmission ADPCM system also uses  $B$  bits (the same number as the ADPCM codec to which it is compared) to code a quantized prediction error. The total number of bits transmitted by the NUT-ADPCM system is then equal to  $B_{NUT} = pNB + N_f$ , where  $p$  is the ratio of transmitted samples and  $N_f$  is the number of the transmitted flags. A flag  $D_n = 1$  is transmitted at each new transmission following a sequence of non-transmitted samples. A flag  $D_n = 0$  is transmitted when the transmission stops. The condition for a profitable use of the NUT-ADPCM system is thus  $pNB + N_f < NB$ . A simplified diagram of the NUT-ADPCM codec described above is presented in Figure 1.

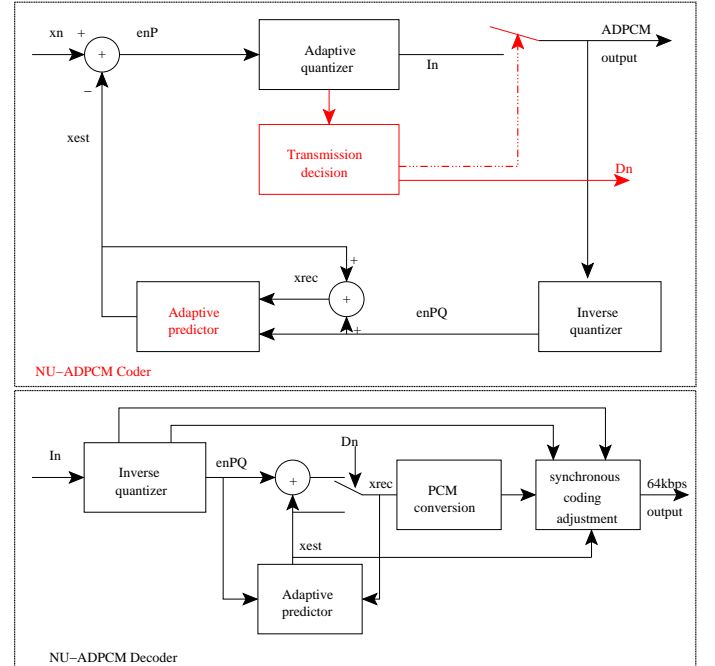

Fig. 1. Simplified diagram of a non-uniform transmission ADPCM coder decoder.

2) *Simulations:* The nonuniform transmission ADPCM system described above is compared here to the ADPCM through simulations on the same speech signal as above. Different values of the number of bits are used to code the prediction error  $B$ . The different methods are coded using MATLAB and executed on a Pentium 4 PC with a 3GHz

processor. The test results are presented in Table II. The term *CPU* in the table indicates the computation time in seconds required by each of the methods.

TABLE II  
COMPARISON OF ADPCM AND NUT-ADPCM

Method	$B$	$p\%$	Bit rate (kbps)	$(\text{SNR})_{dB}$	CPU (s)
ADPCM	2	100	16	4.86	5.5
NUT-ADPCM	2	23	7	11.67	6.6
ADPCM	3	100	24	17.25	5.5
NUT-ADPCM	3	70	20	20.23	7.89
ADPCM	4	100	32	23.5	5.9
NUT-ADPCM	4	85	29	29.78	8.6
ADPCM	5	100	40	29.5	6.1
NUT-ADPCM	5	88	37	33.02	8.9

Referring to Table II, the NUT-ADPCM yields in all cases an improvement in both average transmission bit rate and SNR compared to ADPCM. Moreover, listening tests show a better quality using the NUT-ADPCM method than using the ADPCM for the same number of bits. The performance improvement is nevertheless obtained at the expense of a slight increase in computation time.

## II. CONCLUSION

New nonuniform transmission coding systems were proposed based on nonuniform transmission methods using adaptive parametric prediction methods [11], [12]. Nonuniform transmission was studied in the differential coding case. A nonuniform transmission method for quantized error prediction was proposed. As the prediction error is lower than the quantization error, this method can be considered to be a near-lossless compression method (or even a lossless compression method disregarding the quantization effect). A NUT-ADPCM coding system based on this nonuniform transmission method was described using the same adaptive quantization method as the ADPCM described in the G.726 [1] recommendations. In contrast to the ADPCM, the adaptive-prediction method used in the NUT-ADPCM is the one proposed in [12], thus the signal was modeled by an AR process. In addition, transmission decisions for the quantized prediction errors and the flags were introduced. The NUT-ADPCM coding system was compared to the ADPCM as described in the G.726 recommendations through simulations with speech signals. Improvements in both SNR and average transmission bit rate were observed. Thus, when the prediction errors are coded with four bits (the ADPCM working at 32kbits/s), the NUT-ADPCM coding offers an improvement of 10% in the average bit rate and an improvement of 6dB in the SNR compared to the ADPCM coding system.

## REFERENCES

- [1] "40, 32, 24, 16 kbit/s Adaptive differential pulse code modulation (ADPCM)," *CCITT : Recommendation G.726*, Geneve, 1990.
- [2] J. Makhoul, "Linear prediction: A tutorial review," *Proceedings of the IEEE*, vol. 63, No. 4, pp. 561–580, 1975.
- [3] J. Makhoul and L. Cosell, "Adaptive lattice analysis of speech," *IEEE Trans. on Circuits and Systems*, vol. 28, pp. 494–499, 1981.
- [4] S. Mirsaidi, G. Fleury and J. Oksman, "LMS Like AR modeling in the case of missing observations," *IEEE Trans. on Signal Processing*, vol. 45, No. 6, 1997.
- [5] S. Mirsaidi, G. Fleury and J. Oksman, "Reducing quantization error using prediction/non uniform transmission," *Proceedings of the International Workshop on Sampling Theory and Applications*, Aveiro, Portugal, 1997.
- [6] S. Mirsaidi, G. Fleury and J. Oksman, "An ADPCM-like system based on non uniform signal transmission," *Proceedings of the International Workshop on Sampling Theory and Applications*, Aveiro, Portugal, 1997.
- [7] L. Rabiner and R. Schafer, "Digital processing of speech signals," Prentice Hall, 1978.
- [8] R. Sanchis and P. Albertos, "Recursive identification under scarce measurements-convergence analysis," *Automatica*, vol. 38, pp. 535–544, 2002.
- [9] J. G. Wade, "Codage et traitement du signal," Masson, 1991.
- [10] R. Zgheib, G. Fleury and E. Lahalle, "New fast recursive algorithms for simultaneous reconstruction and identification of AR processes with missing observations," *Proceedings of the fourteenth European Signal Processing Conference, (EUSIPCO)*, Florence, Italy, September 2006.
- [11] R. Zgheib, G. Fleury and E. Lahalle, "New fast algorithm for simultaneous identification and optimal reconstruction of non stationary AR processes with missing observations," *Proceedings of the IEEE twelfth Digital Signal Processing workshop, (DSP)*, Wyoming, USA, September 2006.
- [12] R. Zgheib, G. Fleury et E. Lahalle, "Lattice algorithm for adaptive stable identification and robust reconstruction of non stationary AR processes with missing observations," *IEEE Trans. on Signal Processing*, vol. 56, pp. 2746–2754, 2008.