



HAL
open science

Simulation of a Multi-band Class E PA with a PWM Envelope-coded Signal, for a Multi-radio Transmitter

Antoine Diet, Martha Suarez, Fabien Robert, Martine Villegas, Genevieve Baudoin

► **To cite this version:**

Antoine Diet, Martha Suarez, Fabien Robert, Martine Villegas, Genevieve Baudoin. Simulation of a Multi-band Class E PA with a PWM Envelope-coded Signal, for a Multi-radio Transmitter. International Journal on Communications Antenna and Propagation, 2011, 1 (3), pp.290 - 295. hal-00641204

HAL Id: hal-00641204

<https://centralesupelec.hal.science/hal-00641204v1>

Submitted on 17 Nov 2011

HAL is a multi-disciplinary open access archive for the deposit and dissemination of scientific research documents, whether they are published or not. The documents may come from teaching and research institutions in France or abroad, or from public or private research centers.

L'archive ouverte pluridisciplinaire **HAL**, est destinée au dépôt et à la diffusion de documents scientifiques de niveau recherche, publiés ou non, émanant des établissements d'enseignement et de recherche français ou étrangers, des laboratoires publics ou privés.

Simulation of a Multi-band Class E PA with a PWM Envelope-coded Signal, for a Multi-radio Transmitter

A. Diet¹, M. Suarez-Peñaloza², F. Robert^{3,2}, M. Villegas², G. Baudoin²

Abstract – *This paper focuses on the design of a highly efficient multi-band Power Amplifier (PA), for high Peak to Average Power Ratio (PAPR) signals in the context of a multi-radio transmitter design. Solutions are currently based on polar decomposition of the signal and constant power signal amplification. A simple methodology based on the tuning of an LC network is presented. The goals are to provide high efficiency at several frequency bands. This method implies the collaboration between transient non-linear simulations and frequency simulations/optimization techniques. Once the PA is optimized with a given frequency profile, we tested the amplification of Orthogonal Frequency Division Modulation (OFDM) signal, with Pulse Width Modulation (PWM) envelope coding, and compare with the results of the harmonic simulations. Conclusions are given about such these architectures for multi-radio.*

Keywords: *multi-radio architecture, EER/polar linearization, class E RF PA.*

I. Multi-radio Transmitter Design

Wireless communications are widely used for our daily needs. There are numerous examples which use between 2 and 4 GHz and standard names like BLUETOOTH, WiFi, WiMAX, UMTS and LTE are well-known. An important aspect of today's applications is the increasing data rate need, especially in connectivity standards (WiFi, WiMAX), because of the user's high Quality of Service (QoS) demands. To increase the data rate, we tend to use wideband or multi-standard architecture. The concept of software radio includes a self-reconfigurable radio link [1]-to-[6]. While focusing on the radiofrequency (RF) part, the term multi-radio is preferred. A multi-radio RF device is supposed to use different RF flexible blocks, whose parameters are the centre/carrier frequency, bandwidth, modulation scheme and average power. We focus herein on the transmitter part of such a transmitter.

The signal dynamics (represented by the Peak to Average Power Ratio) should not decrease the transmitter's performance. Due to the different PAPRs of the standard signals (OFDM [5] for example), the transmitter has to be linearised, because the power amplifier (PA) introduces crippling non-linear effects (NL) [4][5]-to-[8]. The present challenge is to linearise the RF architecture, whatever the center frequency (2 to 4 GHz) and the bandwidth are (hundreds of kHz to 20 MHz), while keeping high efficiency because this is related to battery-life. Also the standards coexistence implies difficult filtering challenges, because the unwanted emissions should not lower the receiver's performance. Transmitter's efficiency, linearity and reconfigurability are the figures of merit in a multi-radio architecture [7]-to-[14]. We can separate the architecture

functionalities in two parts. First is the modulation and transposition of the signal and second is the power amplification and filtering requirement for the authorized radiation (by the antenna).

Classical homodyne and heterodyne architecture can be investigated for the modulation and transposition blocks. Such well-known structures are not suitable for different reasons. The heterodyne structure implies additional costly blocks and increase the required selectivity of the filters. The reconfigurability is too complex to introduce in that scenario. The homodyne is a better solution because of its potential reconfigurability, but needs a linearization technique in the context of high PAPR signals. Investigated architectures are based on linearized homodyne solutions which drive them to important modifications of the transmitter. Currently, the Envelope Elimination and Restoration (EER) is a popular linearization technique based on a polar decomposition and recombination of the signal [1][2][5][7][14]-to-[19]. Proposed by Kahn in 1952 [10], the EER/polar linearization technique can be frequency reconfigurable and adapted to wideband and high PAPR multi-radio signals in many different ways. We principally investigate the polar decomposition using an envelope coding process such as Sigma Delta ($\Sigma\Delta$) or Pulse Width Modulation (PWM).

The power amplification and filtering requirements of multi-radio architectures strongly impact the overall efficiency. There are three possibilities for matching efficiency, reconfigurability and spectral requirement at the same time [3]. First solution is a single RF high efficiency and ultra-wideband PA with a filter bank. Such a PA from 2 to 6 GHz is not currently possible, and if it was, the filter bank will introduce too many losses. The second solution is the parallelization of multiple modules

“PA+filter”. This solution has the advantage to optimize each module to a dedicated frequency and signal type. Moreover, this solution is adapted to a multi-standard architecture and need higher flexibility for multi-radio possibility. Unfortunately, the added complexity and necessary size are crippling challenges. The connection to the antenna (wideband or multi-band) also introduces losses. The third solution is the “direct” design of a multi-band high efficiency PA or an easily reconfigurable high efficiency PA [6][7][3]. This solution has the advantage to relax filtering constraints and to potentially optimize the size of the module. This solution is investigated in this paper, in the context of EER/polar transmitter RF architecture.

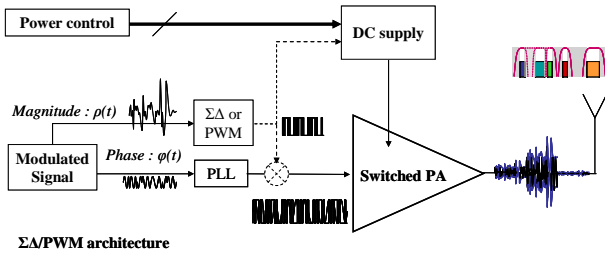

Fig.1: EER/polar RF transmitter architecture

Figure 1 shows the transmitter architecture considered. The polar decomposition enables a constant power signal (phase information after transposition) and the PAPR is managed on the envelope path. To cancel the PAPR influence on the PA, the envelope is coded by $\Sigma\Delta$ or PWM process. This coding enables its recombination by a multiplication with the carrier signal, which is modulated by the phase information. The resulting signal is still constant power. This multiplication can be achieved before the PA or/and by supply modulation, if the PA is in a switched (SW) class such as class D, S, E or F. As RF blocks are flexible, the size of the transmitter is optimized and the system efficiency is directly dependant on the different configurations. Moreover, the design challenge is to keep a highly efficient PA whatever the frequency, the bandwidth, the spectral mask and the power (mean and PAPR) are.

The idea of the front end design is an optimization (frequency sweeping) of a Class E PA. The Class E was chosen for its high efficiency performance and for the small number of reactive components needed, whatever the topology is. As was discussed earlier, PAs for multi-radio can be of three types: broadband, reconfigurable or multi-band. We present in this paper a simple methodology based on previous studies of Class E [4][8][9][11][12][13][16] and optimization processing. A slight increase in the number of reactive components can improve the bandwidth of such a PA (or create a multi-band PA). The tunability of the front-end is improved by an optimization of the output network under HP-ADS. A realistic antenna, designed with CST, is introduced as the load between 2 and 4 GHz, because an antenna with a return loss below -15 dB is not realistic on such a

bandwidth [7]. The design method takes into account the class E theory, the non-linear output impedance of the transistor and a realistic load (the antenna).

The different topologies of the class E PA have been studied and classified in [4][8][9][11][12][13][16]. However, performances are harmonic simulation and testing, and are in good agreement. This work will not add a theoretical part in the class E design. We use the equations developed for parallel based topology and we modify the output network in order to tune the PA to the optimal class E load [16][13][12] at different frequency. Our goal is to design a multi-band PA, presented as one of the three solutions for the “PA+filter” part of the multi-radio (in this paper and in [3]). This makes a strong difference with classical class E design because our goal is to finally simulate the PA driven by a modulated signal (20 MHz bandwidth). The evaluation of the useful efficiency will be done thanks to the spectrum processing.

II. Multi-band Class E PA Design and Optimization

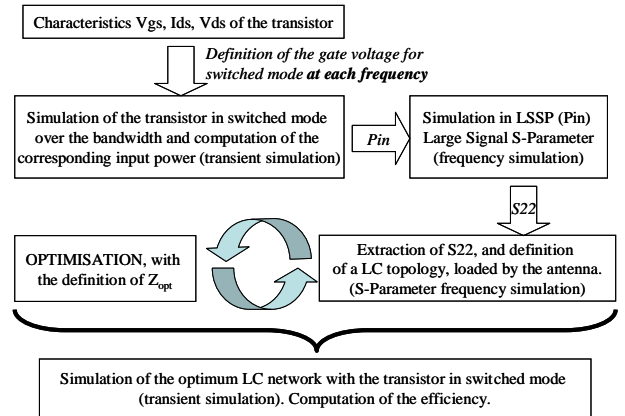

Fig. 2: Proposed design method for the multi-band class E PA

Figure 2 shows the flowchart of the proposed design method. Based on a MESFET Avago ATF 50189, the method consists in four steps: i) Transient simulation with frequency sweeping, to evaluate, between 2 and 4 GHz, the input power necessary for switching operation (P_{in} in Fig. 2). ii) Frequency simulation, with the NL transistor model, to extract the transistor output impedance (S_{22} in Fig. 2) at switching operation. iii) Optimization of an LC output network for class E operation ($Z = Z_{opt}$), taking into account the NL output impedance and the load (antenna). iv). Transient simulation with the transistor and the optimized network, to evaluate the efficiency at different frequency. We will summarize the design step by step.

II.1 Class E PA design principle

Based on theoretical developments concerning class E principle such as in [4][6][8][9][11][12][13][16], we focused on parallel-based topologies with finite DC feed

inductor. The ideal load that must face the ideal transistor (i.e. the “perfect switching” part) is $Z_{opt}(f_{RF}) = 0.8265 R_{load} e^{j34^\circ}$, where R_{load} is the resistive part of the antenna (radiating part) and f_{RF} the centre/carrier frequency [6][13][16][17]. As shown in Fig. 3 the transistor presents non-linear output impedance, simplified as parallel non-linear resistance and capacitor. Class E theory is based on a perfect switch behavior of the transistor. If we extract the parallel non-linear output impedance while the transistor is in switching mode, it can be possible to present the optimal impedance Z_{opt} to the “perfect switching” part of the transistor. However, the amplifier performance evaluation (in terms of efficiency) will still suffer from the influence of the intrinsic and unavoidable non-linear output impedance of the transistor. Once the $S22$ of the transistor in switching mode is extracted, the parallel model can be exploited to simply study the impedance Z composed by: the transistor $S22$ + the output network + the load (the antenna). This impedance can be tuned to Z_{opt} at the desired frequency/ies of operation with an adapted LC network.

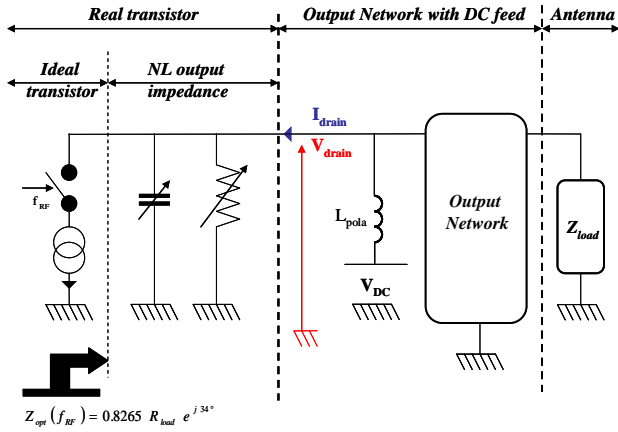

Fig. 3: Class E PA design principle in this study

We define, in (1), a figure of merit for the tuning of Z to Z_{opt} . This criterion is a modification of the matching coefficient Γ with $Z_0 = Z_{opt}$.

$$\Gamma_{\text{class E with } R_{\text{load}}}^{\text{class E}}(Z) = \frac{Z - 0.826 R_{\text{load}} e^{-j34^\circ}}{Z + 0.826 R_{\text{load}} e^{j34^\circ}} \quad (1)$$

The extraction of $S22$ was made thanks to a transient simulation of the transistor, with a feedback controlled gate-to-source voltage to provide the entire switching mode ($V_{\text{pinch-off}}$ to V_{max}). This transient simulation was used to calibrate a large signal S-parameter simulation (LSSP) whose output terminal is the drain-to-source port of the transistor. The resulting $S22$, describing the non-linear parallel impedance of the transistor in switching mode, at different frequencies, is finally obtained and shown in Fig. 4-a).

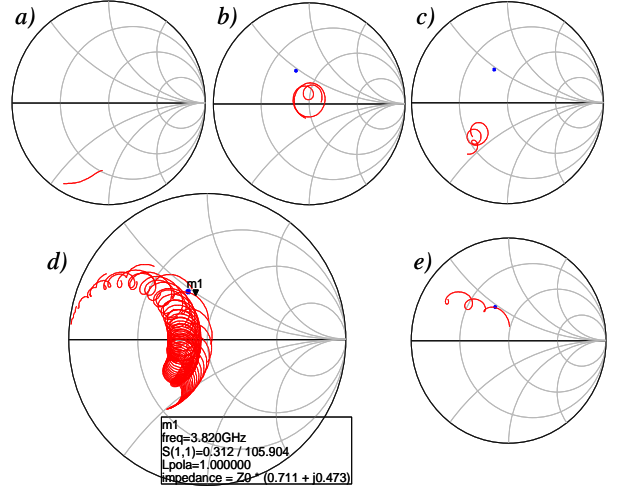

Fig. 4: Impedance composed by a) extracted $S22$, b) the loading antenna, c) $S22$ +antenna, d) parametric L_{pola} and e) $S22 + L_{\text{pola}} = 1\text{nH} + \text{antenna}$.

The antenna used as a load is a Vivaldi type [7] and its return loss is plotted in Fig. 4-b). The parallelization of the $S22$ and the antenna is plotted in Fig. 4-c). The output design network to design is inserted between the antenna and the $S22$. To feed the transistor (drain supply voltage), a parallel inductance is added. Fig. 4-d) is a parametric simulation of the resulting impedance, and enables to choose a polarisation inductance $L_{\text{pola}} = 1\text{ nH}$, in order to be close to Z_{opt} before the design and optimisation of the output network. Fig. 4-e) is the starting point for the conception of the multi-band class E PA output network. The following step is to choose a LC topology, and to optimize its values to obtain $Z = Z_{opt}$ at the wanted frequencies.

II.2 Output network optimization

Topologies for the Class E can be various [13]. Herein, we focus on those using a “filtering cell” composed by a series capacitor and followed by a parallel resonant LC. We select four cases, either for a single band optimisation: UMTS/WiFi (2 to 2,5 GHz) or WiMAX (3,4 to 3,8 GHz), or for both of these bands (2 cases). The dual band optimization needs two roots, implying two cascaded filtering cells, as shown in Fig. 5.

Optimization goals are to match the impedance of the circuit ($S22$ extracted + L_{pola} + output network + antenna) to the optimal class E load Z_{opt} .

We compute the matching coefficient $\Gamma_{\text{class E}}$ defined in (1), according to this criteria and Fig. 5-(bottom) shows the results in four different cases whether we favored the matching for one or two bands. We expect a maximum efficiency at the frequencies where $\Gamma_{\text{class E}}$ is minimal. Once the optimization process meets this goal, the different output networks are incorporated into the final transient simulation, with the transistor non-linear model, in order to evaluate the resulting efficiency and the response to a modulated signal.

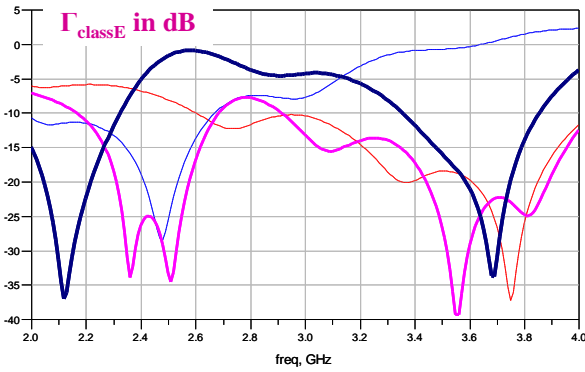
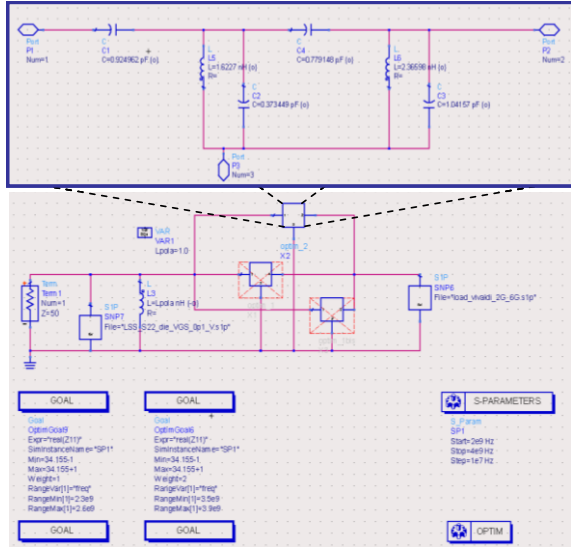

Fig. 5: One optimized topology under ADS (top). Results of the modified matching coefficient defined in (1), for the four cases (bottom).

II.3 Efficiency evaluation under ADS

The efficiency is evaluated under ADS, in a transient simulation, where the transistor is kept in switching mode (harmonic input signal). The output network is loaded by the simulated antenna scattering parameter, see Fig. 5 and 6.

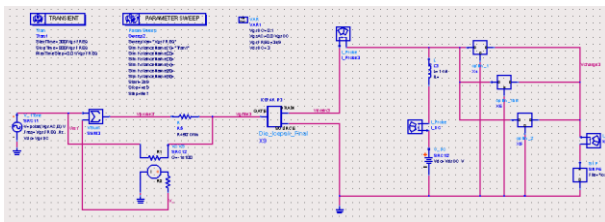

Fig.6: Final transient simulation

To calculate the output power, we extract the resistive part of the load. Results are reported for the four cases (four LC output networks in Fig. 7).

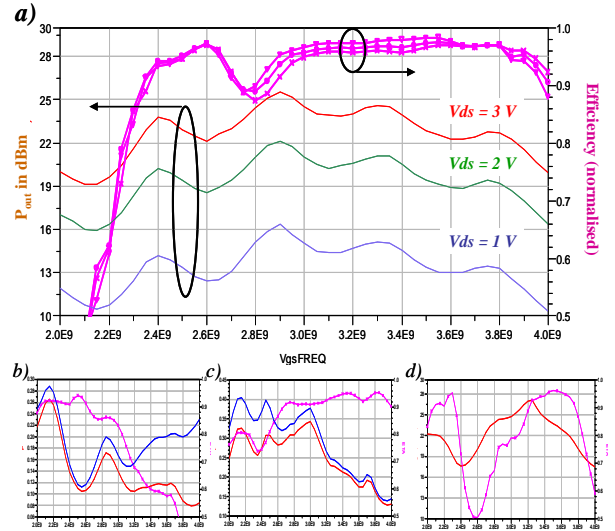

Fig. 7: Results of efficiency evaluation and output/DC power for the four cases: a) dual band, type 1 with variation of the drain voltage b) single band, type 1 c) single band type 2 and d) dual band type 2

All traces in Fig. 7 show a high efficiency in the range of 90%, at the optimized band, with sometimes a slight shifting due to the transistor behavior simplification (hypothesis). Moreover, the output power is highly varying with the frequency. In Fig. 7-a) the drain-to-source voltage is varied additionally to show one important property of switched class PA: the output power is linearly dependant with the supply voltage. This drives it us to consider the future possibilities of envelope tracking/following improvements either for fast (PAPR) or slow (mean power) variations of the output signal amplitude.

The efficiency results are in good agreements with the design method and optimization process. However, this is a classical transient harmonic simulation. For an RF architect, the main transmitter challenges are still: the linearity of the signal and the spectrum mask requirement. In order to evaluate the useful efficiency of any device that would filter the emitted signal, we simulate the PA with a modulated driving signal in the transient simulation.

III. Simulations with a PWM envelope coded signal

Based on the transmitter RF architecture investigated (see part I), we drive the PA with an OFDM signal whose envelope was extracted, PWM coded and recombined. We choose the PWM coding and not the Sigma Delta ($\Sigma\Delta$) because of previous spectrum efficiency evaluation, as reported in [18].

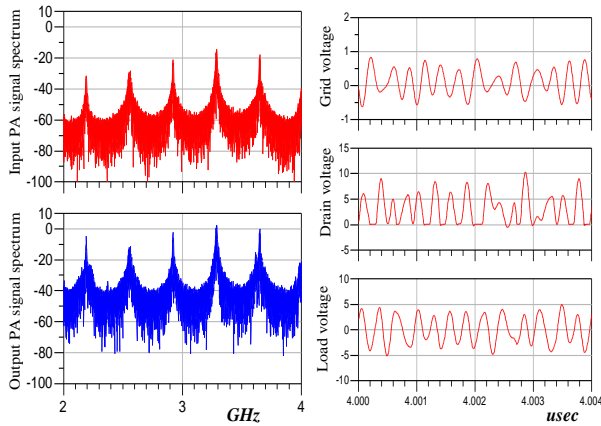

Fig.8: Simulation with an envelope PWM coded signal, spectrum (left) before and after the multi-band PA, and time signals (right)

Fig. 8 shows that timed drain-to-source voltage reveals the hard switching operation of the transistor. On the same figure, the spectrum points out the characteristics of a PWM signal, that is the spectral replicas at each harmonic of the comparison frequency (a frequency reference for the generation of the PWM signal).

The input “constant power” signal, as seen with the grid voltage in Fig. 8, presents amplitude variation due to the bandwidth limitation at the input of the simulation. This filtering is necessary because it will not be realistic to drive any PA with an infinite bandwidth signal. All simulations were done with a 1 to 4 GHz Butterworth order 15 filter function before the PA. The efficiency was firstly evaluated with the entire power delivered to the resistive part of the load and, secondly, with the spectral power evaluation in the 20 MHz channel (around the carrier frequency). Several simulations are reported in Table I. Sometimes out-of-band emissions are tested to compare with in-band signals and the adapted output network. Results in the range of 3 GHz are in agreement with our recent works [18][17] and shows a useful efficiency in the range of 30%. This is due to the important spectral re-growths, created when performing PWM coding (as for $\Sigma\Delta$), which are not enough attenuated by the PA blocs. The bad results of 8% observed in the range of 2 GHz are due to the output power profile of the PA that amplifies unwanted spectral components.

In the context of a wideband and multi-band PA design, we can analyse these results in two main ways: first is that it is impossible to separate the harmonic efficiency performance of the PA from the output power variation of this same PA. The output network optimisation cannot provide surely both properties at the same time. Second is that constant power signals with envelope PWM or $\Sigma\Delta$ coded have to loose part of this property in order not to destroy the signal output spectrum. The risk is to emit high level unauthorized signal at the same time (spectrum mask not respected).

TABLE I
EFFICIENCY EVALUATION FOR SEVERAL SIMULATIONS

Frequency (GHz)	Network type	All band eff. (%)	Filtered signal eff. (%)	Remarks
2,1	Dual n°2	63	8	in-band
2,2	Dual n°2	58	8	in-band
2,3	Dual n°1	55	8	in-band
2,5	Dual n°1	63	15	in-band
2,6	Dual n°2	65	12	out-band
2,8	Dual n°2	54	9,3	out-band
2,8	Dual n°1	76	9	out-band
3,55	Dual n°1	76	47	in-band
3,65	Single n°2	74	34	in-band
3,65	Dual n°2	66	33	in-band

IV. Conclusion

This paper has demonstrated that it is possible to simply design a high efficient PA, if the method is based on harmonic simulations. The modification of the output reactive network enables the efficiency tuning for different frequency bands.

While simulating a modulated signal, the efficiency results highly suffer from both efficiency and output power frequency variation of the PA. Conclusions drive them us to consider the limitation of the PA input signal bandwidth and the contribution of the supply modulation in such architecture.

Another important aspect, evocated in [15], is to remember that a class E PA is biased like a class B one. So this method can/will be modified in the way that the class E operation allows for a sub-optimal class B operation at lower level.

References

- [1] L. Andia Montes, ML Suarez Penaloza, G. Baudoin, M Villegas. “Specifications of a Polar $\Sigma\Delta$ Mobile Multi-Radio Transmitter – Validation on IEEE 802.16e”. *IEEE RWS Conference Proc.*, 2008
- [2] J. Choi et al. “A $\Sigma\Delta$ digitized polar RF transmitter”. *IEEE Trans. on MTT*, Vol. 52, n°12, 2007, pp 2679-2690.
- [3] P. Colantino “Multi-band PA architectural solutions” *Proceedings of European Microwave Week 2009, Whorshop, Rome, 2009.*
- [4] S. Cripps “Advanced techniques in RF Pas design” *Norwood, MA, Artech house, 2002.*
- [5] A. Diet et al. “EER architecture specifications for OFDM transmitter using a class E PA” *IEEE MWCL*, V14 18, 2004, pp 389-391.
- [6] A. Diet et al. “Flexibility of Class E HPA for Cognitive Radio” *IEEE PIMRC 2008, September, Cannes, France.*
- [7] A. Diet et al. “Front end accordability for cognitive multi-radio, using a class E HPA and a multi-band antenna”. *Asia Pacific Microwave Conference, APMC 2008, dec., Hong Kong, China.*

- [8] A. Grebennikov "Class E high efficiency PA: Historical aspects and prospects" *Applied Microwave and Wireless*, 2002, pp 64-71.
- [9] A. Grebennikov, NO Sokal "Switch-mode RF PAs" *Burlington MA, Elsevier*, 2007.
- [10] L. Kahn. "Single Sideband Transmission by Envelope Elimination and Restoration". *Proc. of the I.R.E.*, 1952, pp. 803-806.
- [11] M. Kazimierczuk "Class E tuned PA with shunt inductor" *IEEE journal of Solid State Circuits*, vol 16, February 1981, pp 2-7.
- [12] T. Mader et al. "Switched mode high efficiency microwave PAs in a free space power combiner array" *IEEE trans. on MTT*, Vol 46, October 2008, pp 1391-1398.
- [13] T. Murry, V. Fusco. "Series-L/Parallel-Tuned Class-E Power Amplifier Analysis" *Proceedings of 35th European Microwave Conference*, October 2005.
- [14] M. Nielsen, T. Larsen. "Transmitter Architecture Based on $\Delta\Sigma$ Modulation and Switch-Mode PA". *IEEE Trans. on Circuits and Systems II*, 2007, vol. 54, no. 8, pp. 735-739.
- [15] F. Raab et al. "RF and Microwave PA and Transmitter Technologies" *HF Electronics*, May-November 2003, pp 22-49.
- [16] F. Raab "Idealised operation of the class E tuned PA" *IEEE trans. on Circuits and Systems*, vol. 24, December 1977, pp 725-735.
- [17] F. Robert et al. "Study of a polar $\Delta\Sigma$ transmitter associated to a high efficiency switched mode amplifier for mobile Wimax". *10th annual IEEE Wireless and Microwave Technology Conference, WAMICON*, april 2009, Clearwater, FL, USA. (Best paper award)
- [18] M.-L. Suarez Peñaloza. "Architecture d'émetteurs pour les systèmes de communication multi-radio". (Ph. D report) *Thèse soutenue le 8 décembre 2009, Université Paris-Est*.
- [19] M.-L. Suarez Peñaloza, F. Robert, M. Villegas, G. Baudoin, A. Diet. "Influence of the Envelope coding on a Class E Amplifier Efficiency in Polar Architecture" *European conference on Wireless Technology, EuMW/EuWiT*, 28th Sept. - 2nd Oct. 2009, Roma, Italia.
- [20] N. Sokal, A. Sokal. "Class E, A new Class of high efficiency Tuned switching PAs" *IEEE JSSC*, V10, N3, June 1975, pp 168-176.
- [21] P. J. Hawrylak et al. "Ultra-Low Power Computing System for Wireless Devices". *International Journal on Computers and Software (IRECOS)*, Vol. 1, n. 1, July 2006.

Authors' information

¹ L2S-DRE UMR8506 (UPS-11, CNRS, Supélec). Supélec, rue Joliot Curie, plateau du Moulon, 91192 Gif sur Yvette, France. antoine.diet@lss.supelec.fr

² Université Paris-Est, ESYCOM-ESIEE, EA2552, groupe ESIEE-Paris, 93162 Noisy le Grand, France. {m.suarez, f.robert, m.villegas, g.baudoin}@esiee.fr

³ ST-Ericsson SAS, 12 Rue Jules Horowitz, 38000 Grenoble, France.



Antoine M. Diet was born in France in 1979. He graduated from *ESIEE Paris (Ecole Supérieure d'Ingénieurs en Electronique et Electrotechnique)* in 2001 and received the Ph.D. degree from the *University de Marne la Vallée (UMLV, Paris-Est, France)* in 2005. He is currently associate professor (*Maître de Conférences*) at the *University Paris-Sud 11 (UMR8506 L2S-DRE / IUT de Cachan)*. His research topics concern digital communications wireless architectures, circuits, devices and antennas for wideband (UWB) and multi-band communications systems. He is currently focused on multi-radio front end design.



Martha Suarez is from Bucaramanga, Colombia. She received her degree as Electrical Engineer from the *Universidad Industrial de Santander* in 2004. She received her Master degree and her Ph.D. degree from the *University of Marne-la-Vallee, France* in 2006 and 2009, respectively. She joined the department of Telecommunications and Signal Processing at *ESIEE-Paris (ESYCOM EA2552)*. Currently she is working at the *Instytut Technologii Elektonowej ITE* in Poland for the Partnership for Cognitive Radio Par4CR European Project. Her research interests are in the areas of wireless system architectures and the design of high performance RF transceivers.



Fabien Robert was born in Paris in May 1984. He received the B.S.E.E. degree from *Paris-Est University, France* and *ESTE Paris electronic school*, in 2005 and the M.S.E.E. degree from *ESIEE Paris electronic school*, in 2008 with a specialization in high frequency communication systems. His research interests include switched mode power amplifiers, fully digital transmitter architectures, filtering solutions and CMOS active inductors. Mr. Robert joined *ST-Ericsson, Crolles, France* and *ESYCOM Labs, Noisy le Grand, France* in 2008 where he is finalizing his Ph.D degree.



Martine Villegas graduated from the *Ecole Nationale Supérieure de L'Electronique et des ses Applications (ENSEA)*, Paris, France, in 1981 and received the Habilitation for PHD direction from the *Université de Marne la Vallée* in 2007. After an experience of some years in the industry as designer of microwave monolithic integrated circuits, she joined the world of education & investigation (*École Supérieure d'Ingénieurs en Électronique et Électrotechnique de Paris - ESIEE*) in order to develop the activities in the area of the circuits and systems in radio-frequency and microwaves fields, then in the digital radio communications. She is presently Professor in the department of Telecommunications.



Geneviève Baudoin was born in France in 1954. She graduated from the *école Nationale supérieure des Télécommunications (ENST)*, Paris, France, in 1977 and received the Habilitation for PHD direction from the *Université de Marne la Vallée* in 2000. She was lecturer at the university of Paris-Ouest; then she joined the *Philips Research laboratory* in France, as a research-engineer. Since 1981, she has been with the *École Supérieure d'Ingénieurs en Électronique et Électrotechnique de Paris (ESIEE Paris)*. She is presently Professor with the department of Telecommunications and Signal Processing and Research Director at *ESIEE*. Her research and teaching activities include wireless communications, digital signal processing and speech processing.