



HAL
open science

Compensation of analog imperfections In a Ka-band FMCW SAR

Emilie Avignon, Weixian Liu, Hongchuan Feng, Sylvain Azarian, Marc
Lesturgie, Yilong Lu

► **To cite this version:**

Emilie Avignon, Weixian Liu, Hongchuan Feng, Sylvain Azarian, Marc Lesturgie, et al.. Compensation of analog imperfections In a Ka-band FMCW SAR. 9th European Conference on Synthetic Aperture Radar (EUSAR 2012), Apr 2012, Nuremberg, Germany. pp.60-63. hal-00752229

HAL Id: hal-00752229

<https://centralesupelec.hal.science/hal-00752229>

Submitted on 15 Nov 2012

HAL is a multi-disciplinary open access archive for the deposit and dissemination of scientific research documents, whether they are published or not. The documents may come from teaching and research institutions in France or abroad, or from public or private research centers.

L'archive ouverte pluridisciplinaire **HAL**, est destinée au dépôt et à la diffusion de documents scientifiques de niveau recherche, publiés ou non, émanant des établissements d'enseignement et de recherche français ou étrangers, des laboratoires publics ou privés.

Compensation of Analog Imperfections In a Ka-band FMCW SAR

Emilie Avignon-Meseldzija, Supélec, France

Weixian Liu, Temasek Laboratories, Nanyang Technological University, Singapore

Hongchuan Feng, Temasek Laboratories, Nanyang Technological University, Singapore

Sylvain Azarian, Supélec, France

Marc Lesturgie, Supélec, France

Yilong Lu, Temasek Laboratories, Nanyang Technological University, Singapore

Abstract

This paper deals with the compensation of analog imperfections in a Ka-Band FMCW SAR. Due to the presence of phase distortion in the up-conversion and down-conversion block, we demonstrate that the calibration of the VCO based on a reference beat signal is range-limited. We propose a post-processing method to compensate the residual sinusoidal nonlinearities of the VCO characteristic as well as the phase distortion coming from the up-conversion and down-conversion block. Processing of SAR data acquisition demonstrates the efficiency of the method.

1 Introduction

Ka-Band FMCW (Frequency Modulated Continuous Wave) SAR (Synthetic Aperture Radar) systems are of great interest for high-resolution embedded applications like UAV (Unmanned Aerial Vehicle) [1]. The design of a Ka-Band SAR can be performed using low-cost devices, mostly low-cost analog devices. But often, a great effort has to be made, based on these analog components to reach the desired performances. Especially concerning the VCO (Voltage Controlled Oscillator) frequency characteristic which presents strong nonlinearities. The literature on the subject is well-developed. Some approaches are based on a PLL to get a linear chirp signal [1], other approaches are based on the generation of a matched pre-distorted voltage command to obtain the linear frequency characteristic [2]. The generation of this pre-distorted command can be made based on an acquisition of the VCO frequency characteristic measured for example with a signal analyzer. We will call it an open-loop calibration (figure 1, red path). The generation of the pre-distorted command can also be based on an acquisition of the beat signal using a delay line [2][3]. This is a closed-loop calibration (figure 1, green path). The use of a pre-distorted command is very efficient for the nonlinearities that can be approximated by a polynomial expression. But another concern is the residual errors which are random as well as deterministic. Several methods have been developed to mitigate these residual errors. In [4] the residual nonlinearities (deterministic as well as random) are measured simultaneously at each sweep thanks to an additional path in the radar and then corrected by making the assumption that the strength of phase error is proportional to the range. A complete compensation of the residual phase nonlinearities of

the VCO is achieved based on a measurement on the beat signal and the Residual Video Phase removal algorithm in [5], assuming that all the nonlinearities only come from the transmitted chirp.

In this paper, we assume that the imperfections not only come from the VCO but also from the up-conversion and down-conversion block. Considering these imperfections, we discuss the range validity of a closed-loop calibration of the VCO and propose a post-processing method to correct the strong sinusoidal nonlinearities coming from the VCO as well as the phase distortion coming from the up-conversion and down-conversion block. Figure 1 gives the architecture of the commercial radar used, purchased from Frontier Integrated Technology Pte. Ltd.

In part 2 we discuss the effect of the phase distortion in the up-conversion and down-conversion block and demonstrate that generating a pre-distorted command based on a closed loop calibration give better results for this particular range but worse results for the other range. In part 3 we highlight the dramatic effect of residual sinusoidal nonlinearities of the frequency characteristic of the VCO and propose a post-processing phase correction method which corrects both the sinusoidal nonlinearities and the transceiver phase distortion. In part 4 we present measurement results of the SAR with the proposed post-processing.

2 Discussion on phase distortion compensation

2.1 Effect of phase distortion of transceiver block

Usually, great attention is paid in FMCW radar to ensure that the VCO chirp is linear using a pre-distorted

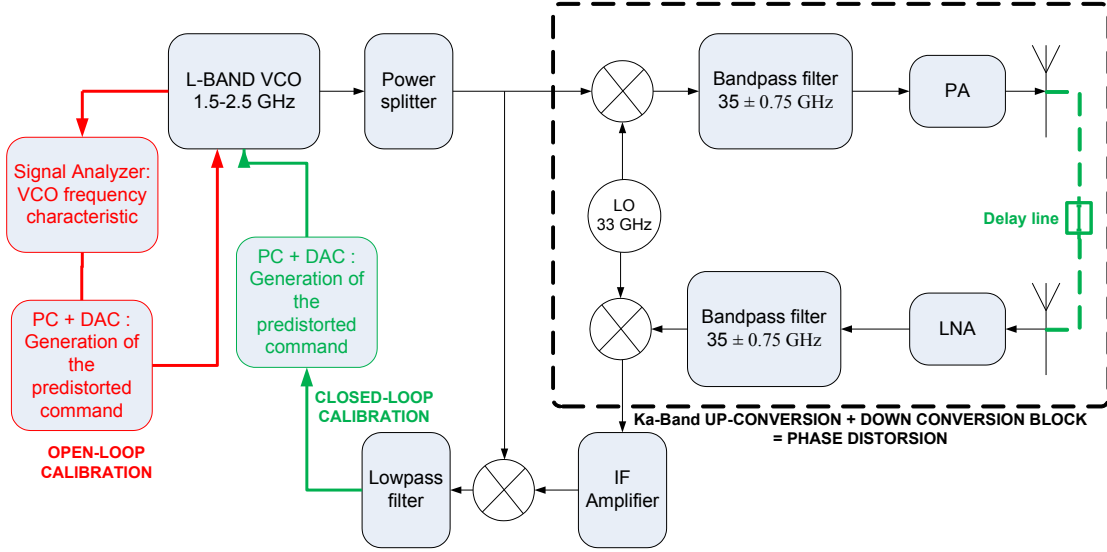

Figure 1: transceiver architecture

voltage command. But the up-conversion and down-conversion block, showed in figure 1, constituted by a PA, a LNA, mixers, an IF amplifier, and band-pass filters will generate a global non-negligible phase distortion. To highlight the effect of this phase distortion we assume that we have a perfectly linear chirp in the L-Band (1.5 – 2.5 GHz) before the up-conversion block. The phase of this chirp, used as a reference in reception for the de-chirping may be written as:

$$\varphi_{trans}(t) = At + Bt^2 \quad (1)$$

Where for a $T=1\text{ ms}$ sweep, $A=3 \cdot \pi \cdot 10^9$ and $B=\pi \cdot 10^{12}$. If we approximate the phase distortion in the up-conversion and down-conversion block as an n-th order polynomial expression:

$$\varphi_{dist}(t) = k_1t + k_2t^2 + k_3t^3 \dots + k_nt^n \quad (2)$$

Then, the phase of the chirp received, after down-conversion, from a single target can be written as:

$$\varphi_{receiv}(t) = (A + k_1)(t - \tau) + (B + k_2)(t - \tau)^2 + k_3(t - \tau)^3 \dots + k_n(t - \tau)^n \quad (3)$$

With τ the round-trip delay to the target. So the frequency of the beat signal, instead of being equal to $B\tau/\pi$, results in an (n-1)-th order polynomial expression. To illustrate, hereafter is the expression of the beat frequency for a third-order phase distortion in the transceiver block:

$$f_{beat}(t) = (1/2\pi) \cdot$$

$$[(-k_1 + 2B\tau + 2k_2 - 3k_3\tau^2) + 2t(-k_2 + 3k_3\tau) - 3k_3t^2] \quad (4)$$

This non-stationarity of the beat signal leads to a spread of energy in the spectrum. The FFT of the beat signal then presents higher side-lobes and the main lobe may be shifted compared to the ideal case. Figure 2 presents the frequency characteristic of the beat signal for the following phase distortion parameters in the up-conversion and down conversion block: $k_1=-1000$, $k_2=10^5$, $k_3=-5 \cdot 10^9$. To later quantify the impact of the phase distortion error on the beat signal we will use the area between the ideal beat frequency and the distorted one (see figure 2):

$$error = \int_0^T \left(f_{beat}(t) - \frac{B\tau}{\pi} \right) dt \quad (5)$$

The greater this area is, the greater the degradation of the performances (possible shift of the main lobe and higher side lobes).

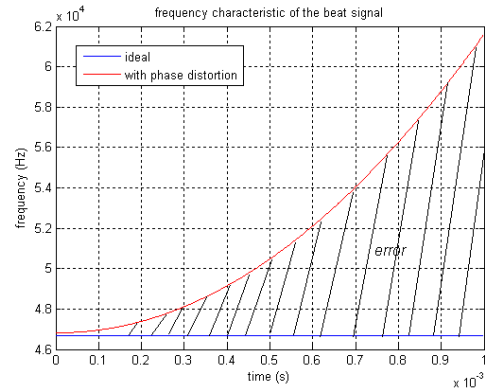

Figure 2: error in the beat frequency

As we will see in the following part, it is possible to compensate for this error at a particular range through a closed-loop calibration but the error will increase as soon as we move away from the calibration range.

2.2 Range validity of closed-loop calibration

The closed-loop calibration allows one to deduce the VCO frequency characteristic from the beat signal, and so generate the suitable pre-distorted command. But as soon as we have phase distortion in the transceiver chain the frequency characteristic that is deduced, is no longer the true VCO characteristic but a global frequency characteristic including the phase distortion. For example, we again consider the case presented in part 2.1 (same distortion parameters). Based on the phase of the beat signal, instead of the real phase of the linear chirp expressed in (1), the deduced VCO phase characteristic will be:

$$\varphi_{trans_deduced}(t) = a_1t + b_1t^2 + c_1t^3 + d_1t^4 \quad (6)$$

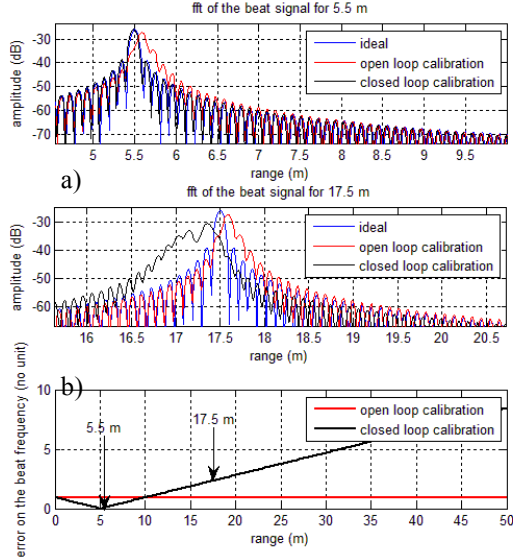

Where: ^c

Figure 3: comparison of closed loop/open loop with simulation results

$$\begin{cases} c_1 = \frac{-k_2 + 3k_3\tau + 6\tau^2 d_1}{3\tau} \\ b_1 = \frac{-k_1 + 2(B+k_2)\tau + 3(c_1 - k_3)\tau^2 - 4d_1\tau^3}{2\tau} \\ a_1 = A + k_1 - (b_1 + B + k_2)\tau + (k_3 - c_1)\tau^2 + d_1\tau^3 \end{cases} \quad (7)$$

As can be seen from (7), the phase characteristic deduced from the beat signal depends on the delay (range). It means that the calculated pre-distorted command depends on the range and will not be suitable for the other ranges. To illustrate this fact figure 3.a presents the FFT of a simulated beat signal for a 5.5 m range when the correction has been calculated for a 5 m range. For this distance the closed-loop calibration gives a better result than the open-loop calibration. Fig. 3.b presents the result obtained with the same 5 m-closed loop calibration but for a 17.5 m range. In this case, the closed loop calibration is much worse than the open loop calibration. The figure 3.c presents the error as defined in (5) for the two calibrations depending on the range; between 0 and 10 m, the closed-loop calibration will give better performances than the open-loop calibration. Outside this range the open-loop calibration gives better performances. For the open-loop calibration the error remains constant. So a pre-distorted command generated with an open-loop calibration will give more robust results. And the correction of the residual phase distortion can be achieved by the post-processing method presented in the following part.

3 Post-processing compensation of residual nonlinearities

3.1 Effect of residual nonlinearities

After compensation with a pre-distorted command, the VCO frequency characteristic still presents some residual nonlinearities. One part of these nonlinearities is random and the other part is deterministic. These nonlinearities result in a phase error term in the beat signal, that we will call $\Delta\varphi_{beat}(t)$. The noisy beat signal, obtained during one period of chirp, can then be expressed as:

$$beat_{noisy}(t) = E_0 \cos(A\tau - B\tau^2 + 2Bt\tau + \Delta\varphi_{beat}(t)) \cdot \Pi_T(t) \quad (8)$$

This is equivalent in the exponential form to:

$$beat_{noisy}(t) = (E_0/2) \cdot [e^{i(A\tau - B\tau^2 + 2Bt\tau + \Delta\varphi_{beat}(t))} + e^{-i(A\tau - B\tau^2 + 2Bt\tau + \Delta\varphi_{beat}(t))}] \cdot \Pi_T(t) \quad (9)$$

From (9) we can calculate the Fourier Transform in the ideal case ($\Delta\varphi_{beat}(t) = 0$) and observe that we should have two pure Sinc in the frequency domain:

$$Beat_{ideal}(f) = \frac{E_0}{2} \left(T e^{i(A\tau - B\tau^2 + T(B\tau - \pi f))} \text{sinc}(T(B\tau - \pi f)) + T e^{-i(A\tau - B\tau^2 - T(B\tau - \pi f))} \text{sinc}(T(-B\tau - \pi f)) \right) \quad (10)$$

If we call F_s the sampling frequency used to make the acquisition of the beat signal, the FFT-location of the two Sinc will be $B\tau/\pi$ and $F_s - B\tau/\pi$. The second one, which is not useful, is usually removed by a low-pass filter.

Due to the presence of $\Delta\varphi_{beat}(t)$, we will obtain two noisy Sinc. The part of $\Delta\varphi_{beat}(t)$ which degrades the expected Sinc most is the deterministic part. This part comes mainly from the VCO residual errors which are approximately sinusoidal and which dramatically reduce the dynamic range of the radar [6] but also from the phase distortion mentioned previously.

3.2 Global correction of residual nonlinearities

As the deterministic part of the error is the part that has the most impact on the degradation of the beat signal, we propose a correction based on the measurement of the mean value of the errors $\Delta\varphi_{beat}(t)$. This method presents the advantage of not needing an incorporated delay line in the radar. It also corrects the phase distortion coming from the transceiver block and the residual nonlinearities coming from the VCO at the same time.

The first step of the method is to evaluate $\Delta\varphi_{mean}(t)$ the mean value of $\Delta\varphi_{beat}(t)$ based on several beat signal acquisitions. For that we can use either one-target acquisitions, or several-target acquisitions. If several-target acquisitions are used, one target has to be selected in the frequency domain thanks to a bandpass filter. On each acquisition the phase of the one-target-beat signal is calculated by the following process:

$$\varphi_{beat}(t) = \arctan\left(\frac{\text{imag}(\text{IFFT}(\text{half_FFT}(\text{beat}(t))))}{\text{real}(\text{IFFT}(\text{half_FFT}(\text{beat}(t))))}\right) \quad (11)$$

Then $\Delta\varphi_{beat}(t)$ of each acquisition is calculated by calculating the difference between the linear phase obtained by a first order interpolation and the real phase obtained by (11). After that, the mean value of

this difference ($\Delta\varphi_{mean}(t)$) is calculated, stored and used to correct every range profile from a SAR acquisition by a simple multiplication. The corrected beat signal can be expressed as:

$$beat_{cor}(t) = E_0 \cos(A\tau - B\tau^2 + 2Bt\tau + \Delta\varphi_{beat}(t)) \cdot e^{-i\Delta\varphi_{mean}(t)} \cdot \Pi_T(t) \quad (12)$$

Since we assumed previously that the strongest part of $\Delta\varphi_{beat}(t)$ is the deterministic part, we consider that $\Delta\varphi_{mean}(t) \approx \Delta\varphi_{beat}(t)$ the corrected beat signal can then be approximated by:

$$beat_{cor}(t) = (E_0/2) \cdot [e^{i(A\tau - B\tau^2 + 2Bt\tau)} + e^{-i(A\tau - B\tau^2 + 2Bt\tau + 2\Delta\varphi_{beat}(t))}] \cdot \Pi_T(t) \quad (13)$$

We have seen previously that this results in a two-part spectrum. But thanks to the correction, the first part of the spectrum is now cleaned of the nonlinearities which are concentrated in the non-useful symmetrical part which is removed by a low-pass filter. Figure 4 presents the result of the correction applied on a real case for a target at a range of about 6 m. As expected, we notice a great reduction of the side-lobes which proves that most of the phase nonlinearities have been compensated for.

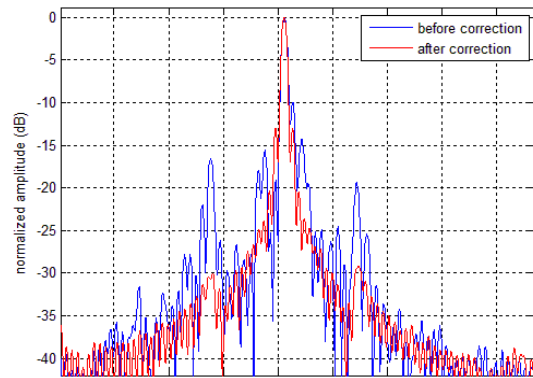

Figure 4: correction of phase nonlinearities

4 Measurement results

Acquisitions of raw data have been made with a couple of reflectors at a range of about 20 m. The VCO is driven by the pre-distorted command generated in open-loop. Figure 5 presents the resulting SAR image before the correction of the nonlinearities (top image) and after the correction of the nonlinearities (below image). On the top image the white arrows indicate the location of side-lobes resulting from the phase nonlinearities. We can observe in the image below that these side-lobes are weaker, giving a better energy focus, proving that the post-processing method is efficient.

5 Conclusion

The paper has presented a study of the range-dependent aspect of the closed-loop calibration due to phase distortion coming from the up-conversion and down-conversion block of a Ka-Band radar. A post-processing method correcting both the phase distortion of the up-conversion and down-conversion block as well as the strong sinusoidal nonlinearities coming

from the VCO has been provided and tested on a real SAR acquisition.

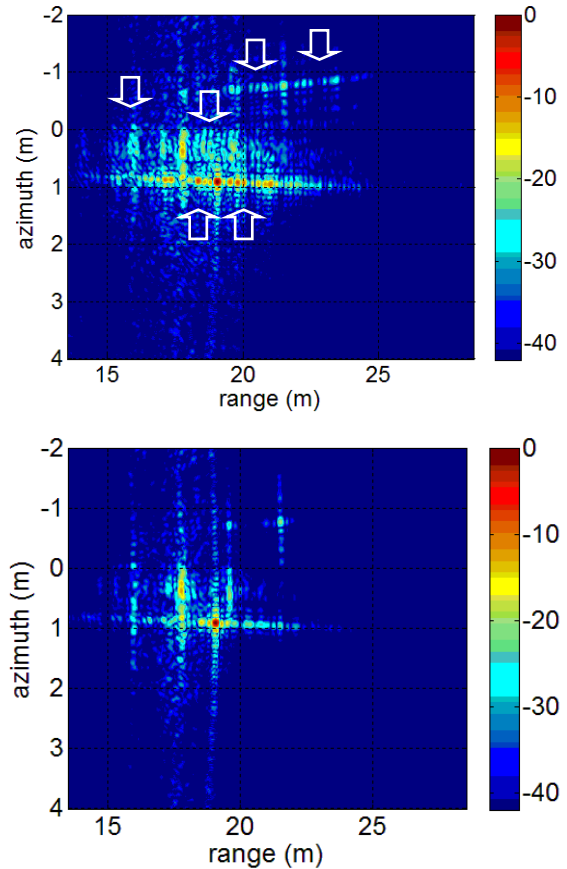

Figure 5: SAR images, top: before processing, below: after processing

References

- [1] Jose-Tomas Gonzalez-Partida, Pablo Almorox-Gonzalez, Mateo Burgos-Garcia, Blas-Pablo Dorta-Naranjo "SAR System for UAV Operation With Motion Error Compensation beyond the Resolution Cell," *Sensors*, vol. 8, issue 5, pp. 3384-3405, May. 2008.
- [2] Li Li, Jason Lu, Jeffrey Krolik, "Software-defined Calibration for FMCW Phased-Array radar" *IEEE Radar Conference*, vol. 20, pp. 877 - 881, Washington DC, May. 2010.
- [3] Jorn Fuchs, Keith D. Ward, Marshall P. Tulin, and Robert A. York, "Simple techniques to correct for VCO nonlinearities in short range FMCW radars" *IEEE MTT-S Digest*, pp. 1175- 1178, 1996.
- [4] M. Vossiek, P. Heide, M. Nalezinski, V. Magori, "Novel FMCW radar system concept with adaptive compensation of phase errors" *26th European Microwave Conference*, pp. 135 - 139, Prague, Sept 1996.
- [5] Adriano Meta, Peter Hoogeboom and Leo P. Ligthart, "Range non-linearities correction in FMCW SAR" *IEEE International Conference on Geoscience and Remote Sensing Symposium*, pp. 403 - 406, Aug 2006.
- [6] Samuel O. Piper, "Homodyne FMCW Radar Range Resolution Effects with Sinusoidal Nonlinearities in the Frequency Sweep" *IEEE International Radar Conference*, pp. 563 - 567, May 1995.