



HAL
open science

A Novel Architecture for Differential Resonant Sensing

J rome Juillard, Alain Bonnoit, Nuria Barniol, Arantxa Uranga, Gabriel Vidal-Alvarez

► **To cite this version:**

J rome Juillard, Alain Bonnoit, Nuria Barniol, Arantxa Uranga, Gabriel Vidal-Alvarez. A Novel Architecture for Differential Resonant Sensing. Eurosensors 2014, Sep 2014, Brescia, Italy. pp.1573 - 1576, 10.1016/j.proeng.2014.11.601 . hal-01103768

HAL Id: hal-01103768

<https://centralesupelec.hal.science/hal-01103768v1>

Submitted on 15 Jan 2015

HAL is a multi-disciplinary open access archive for the deposit and dissemination of scientific research documents, whether they are published or not. The documents may come from teaching and research institutions in France or abroad, or from public or private research centers.

L'archive ouverte pluridisciplinaire **HAL**, est destin e au d p t et   la diffusion de documents scientifiques de niveau recherche, publi s ou non,  manant des  tablissements d'enseignement et de recherche fran ais ou  trangers, des laboratoires publics ou priv s.

A novel architecture for differential resonant sensing

J. Juillard¹, A. Bonnoit¹, N. Barniol², A. Uranga², G. Vidal-Alvarez²

¹Dpt. of Signal Processing and Electronic Systems, SUPELEC, Gif-sur-Yvette, France

²Dpt. of Electrical Engineering, UAB, Barcelona, Spain

Summary

In this paper, the basic principles of a novel differential resonant sensing architecture are explained, illustrated and experimentally validated. We describe how a digital mixer architecture may be built in order to enforce a mutually injection-locked oscillation state in two M/NEMS resonators. It is shown that, in this state, the phase difference between the two resonators is highly sensitive to mismatch and can be used to sense changes of physical quantities, whereas it is largely unaffected by drift (e.g. induced by unwanted changes in environmental conditions). Some results obtained with a PCB-mounted discrete-component mixer and two NEMS resonators co-integrated with an analog front-end validate this approach.

Motivation and results

Cross-coupled, injection-locked electronic oscillators based on LC-tank resonators are commonly used to generate very stable, multiphase (typically quadrature) clock signals in high-frequency IC applications [1-2]. It is well-known that the phase error and the phase noise of these oscillators are highly sensitive to the mismatch between the resonators. While this sensitivity to mismatch is a major drawback for clocking applications, it can be turned into an advantage for a sensing application, if the mismatch of the resonators is designed to depend on the quantity to be sensed.

Our key idea is then to take advantage of the mismatch sensitivity of injection-locked oscillator architectures for resonant-sensing applications: the LC-tanks are replaced with M/NEMS resonators (one of which is used as a reference sensor) whose output signals are amplified, mixed and fed back to them in order to ensure oscillation and locking (Fig. 1). In theory (Fig. 2), this should result in an *inherently drift-free* measurement and in an *improved resolution and stability* compared to classical (i.e. not injection-locked) differential resonant sensing architectures [3]. In fact, theory predicts that the injection-locked measurement (in which the phase difference between the resonators is measured) should be of the order of Q times more sensitive than the classical measurement method (in which the oscillation frequency is measured), where Q is the quality factor of the resonators. Moreover, compared to the most accurate state-of-the-art differential or absolute resonant sensing schemes based on PLLs [4], our approach does not require a high-quality VCO (e.g. based on a quartz) and it can be implemented with only digital components: *it should thus be fully-compatible with VLSI fabrication processes and should also be easier to design and less area-consuming than current state-of-the-art solutions.*

A proof of concept of this approach is given, in which two separate tungsten cantilever beam resonators (with dimensions 10 μ m length, 500nm width, 900 nm thickness and actuation gap of 450nm, yielding a natural frequency of 3.4MHz and a quality factor of 100) monolithically integrated in AMS 0.35 μ m technology with a CMOS amplifier [5] are cross-coupled with a PCB-mounted discrete-component mixer (Fig. 3-4). The results obtained when changing the electrostatic stiffness of one of the resonators (Fig. 5), in order to modulate its natural resonance frequency, demonstrate the enhanced sensitivity of this sensing mode compared to the classical sensing mode, as predicted by theory.

References

- [1] A Mazzanti et al., "On the Amplitude and Phase Errors of Quadrature LC-Tank CMOS Oscillators", IEEE Journal of Solid-State circuits, vol. 41, pp. 1305-1313, 2007
- [2] A. Mirzaei et al., "The Quadrature LC Oscillator: A Complete Portrait Based on Injection Locking", IEEE Journal of Solid-State circuits, vol. 42, pp. 1916-1932, 2007
- [3] A. A. Trusov et al., "Silicon Accelerometer with Differential Frequency Modulation and Continuous Self-Calibration", MEMS Conference, pp. 29-32, 2013
- [4] C. Cobianu and B. Serban, "All-differential resonant nanosensor apparatus and method", US Patent 0113856 A1, 2011
- [5] A. Uranga et al., "Exploitation of non-linearities in CMOS-NEMS electrostatic resonators for mechanical memories", Sensors and Actuators A, vol. 197, pp. 88-95, 2013

Word count: 497

Corresponding author: Jérôme Juillard, SUPELEC, 3 rue Joliot-Curie, 91192 Gif-sur-Yvette, FRANCE, +33 -1- 69 85 14 08, jerome.juillard@supelec.fr

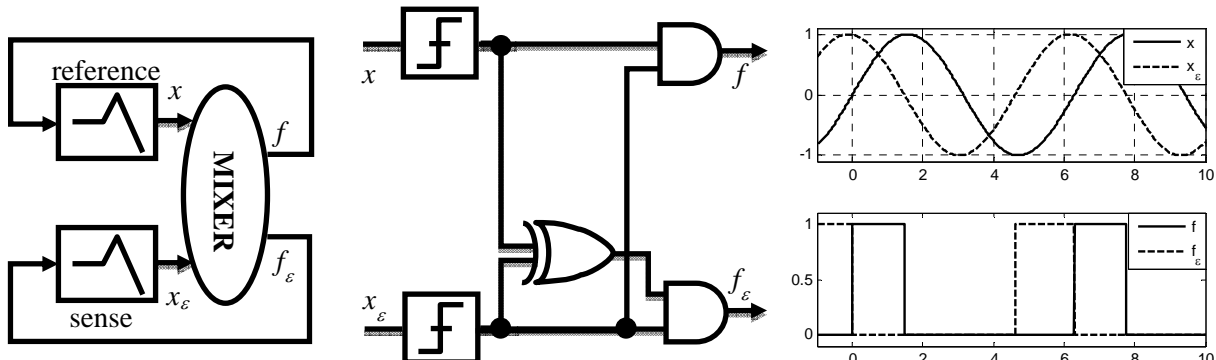

Fig. 1 – General differential resonant sensing architectures (left) consist of two resonators in a state of mutual injection-locking, enforced by a mixer. The considered mixer (middle) ensures that the two signals resonators oscillate in quadrature if they are perfectly matched. Typical waveforms are shown on the right.

$$\begin{cases} \omega_0^2 x + \omega_0 \frac{\dot{x}}{Q} + \ddot{x} = f \\ (1 + \epsilon)\omega_0^2 x_\epsilon + \omega_0 \frac{\dot{x}_\epsilon}{Q} + \ddot{x}_\epsilon = f_\epsilon \end{cases} \Rightarrow \begin{cases} \cot \phi = \frac{Q}{2} \epsilon \frac{\omega}{\omega_0} \\ A = A_\epsilon \\ \omega \approx \omega_0 (1 + \epsilon)^{1/2} \end{cases}$$

$$\begin{cases} x \approx A \sin(\omega t) \\ x_\epsilon \approx A_\epsilon \sin(\omega t + \phi) \end{cases} \quad (\text{if } \epsilon \gg 1/Q)$$

Fig. 2 – The mutually-injection-locked state can be analyzed with the method of averaging, showing that the phase delay ϕ is ideally Q times more sensitive than the oscillation frequency ω to changes in the quantity of interest (ϵ) and is immune to (drift-induced) changes in ω_0 .

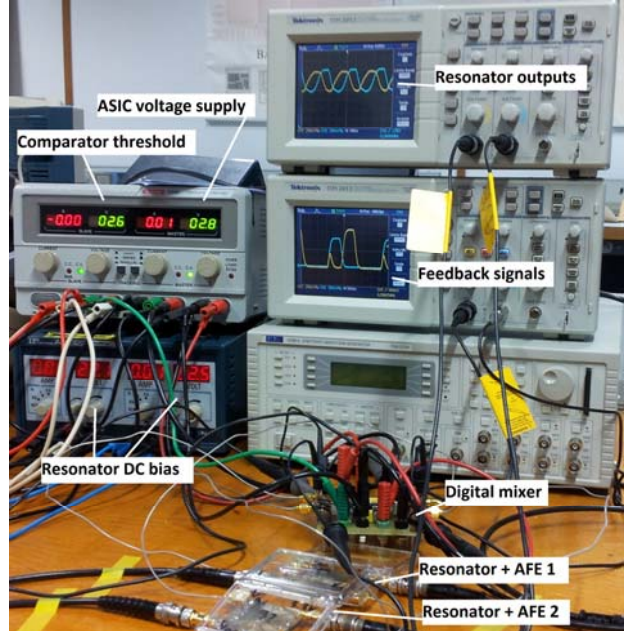

Fig. 3 – Experimental setup. The mixer consists of two AD8561 comparators, one 74HCT08 AND gate, one 74HCT86 XOR gate and two variable resistors to adjust the actuation voltage. The inset shows the open-loop frequency response of the resonators.



Fig. 4 – Measured feedback (top) and output (bottom) waveforms. The output waveforms are slightly distorted due to feedthrough and saturation effects. The duty cycle of the feedback waveforms is a direct measurement of the phase delay ϕ .

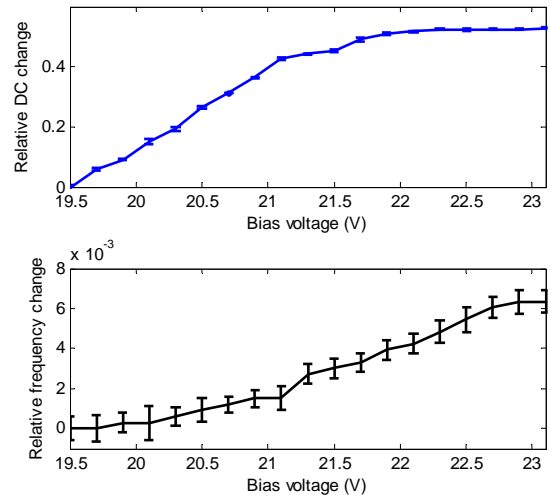

Fig. 5 – In the mutual injection-locking regime, the relative duty cycle change (top) is about 100 times greater than the relative oscillation frequency change (bottom) as the bias voltage of one of the resonators is changed. In spite of discrepancies (that can be attributed to distortion, feedthrough and phase delay in the AFE), this result is consistent with theory (Fig. 2).