



**HAL**  
open science

## Calculation of the equivalent mutual impedance in complex HF RFID systems

Megdouda Benamara, Marjorie Grzeskowiak, Gaelle Bazin Lissorgues, A. Diet, Yann Le Bihan, Christophe Conessa

### ► To cite this version:

Megdouda Benamara, Marjorie Grzeskowiak, Gaelle Bazin Lissorgues, A. Diet, Yann Le Bihan, et al.. Calculation of the equivalent mutual impedance in complex HF RFID systems. 2016 22nd International Conference on Applied Electromagnetics and Communications (ICECOM), Sep 2016, Dubrovnik, Croatia. pp.1-4, 10.1109/ICECom.2016.7843884 . hal-01691597

**HAL Id: hal-01691597**

**<https://centralesupelec.hal.science/hal-01691597v1>**

Submitted on 31 Jul 2019

**HAL** is a multi-disciplinary open access archive for the deposit and dissemination of scientific research documents, whether they are published or not. The documents may come from teaching and research institutions in France or abroad, or from public or private research centers.

L'archive ouverte pluridisciplinaire **HAL**, est destinée au dépôt et à la diffusion de documents scientifiques de niveau recherche, publiés ou non, émanant des établissements d'enseignement et de recherche français ou étrangers, des laboratoires publics ou privés.



## Open Archive Toulouse Archive Ouverte (OATAO)

OATAO is an open access repository that collects the work of some Toulouse researchers and makes it freely available over the web where possible.

This is an author's version published in: <https://oatao.univ-toulouse.fr/24083>

**Official URL:** <https://doi.org/10.1109/ICECom.2016.7843884>

### To cite this version :

Benamara, Megdouda and Grzeskowiak, Marjorie and Lissorgues, Gaëlle and Diet, Antoine and Le Bihan, Yann and Conessa, Christophe Calculation of the equivalent mutual impedance in complex HF RFID systems. (2016) In: 2016 22nd International Conference on Applied Electromagnetics and Communications (ICECOM), 19 September 2016 - 21 September 2016 (Dubrovnik, Croatia).

Any correspondence concerning this service should be sent to the repository administrator:

[tech-oatao@listes-diff.inp-toulouse.fr](mailto:tech-oatao@listes-diff.inp-toulouse.fr)

# Calculation of the Equivalent Mutual Impedance in Complex HF RFID Systems

M. BENAMARA, M. GRZESKOWIAK, G. LISSORGUES

ESYCOM EA 2552 (UPEMLV, ESIEE-Paris, CNAM)  
Cite Descartes, BP99, 93162 Noisy le Grand, France  
Cite Descartes, F. 77454 Marne-la-Vallée, France  
benamara@univ-mlv.fr

A. DIET, Y. LE BIHAN, C. CONESSA  
GEEPS (PIEM) UMR 8507, Univ. Paris Saclay  
F. 91192 Gif sur Yvette, France

**Abstract**— In this work the improvement of HF RFID detection is obtained by the addition of small resonator in the reader coil. In conventional RFID system, the link between the reader and the tag coils is the mutual inductance, the added resonator is magnetically coupled with the reader coil, and then the link is expressed by the mutual impedance. Theoretical calculation of the equivalent mutual impedance of such system is reported and validated by comparison with HFSS simulation and measures.

**Keywords**— rfid; mutual impedance; HF

## I. INTRODUCTION

An inductively coupled RFID HF system is based on the magnetic coupling between the reader and the tag coils. In the case of weak coupling, the detection performance of the tag is fruitfully evaluated by the mutual inductance as a figure of merit [1][2][3][4]. A current challenge in HF RFID is to increase the surface and, if possible, the volume of detection by customizing the shape of the reader antenna [5][6][7]. More precisely, a way of improvement is studied and obtained by the addition of a small resonator coil. The addition of a resonator concentrates and modifies the vectorial distribution of the magnetic field generated by the reader, as it can be shown in Fig.1. Accordingly, optimal detection areas can appear.

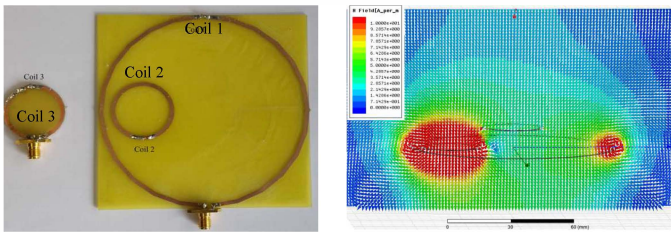

Fig. 1. Proposed structure and its generate magnetic field

In the following section of this paper, we investigate the formula defining equivalent mutual impedance between the dual-coils structure and the tag coil, and validate these relations, in section III, by simulations under HFSS (High Frequency Structure Simulator) and measurements using a Vectorial Network Analyzer.

## II. ANALYTICAL CALCULATION OF THE EQUIVALENT IMPEDANCE MATRIX

Fig.2 is the electrical model of the system composed by the dual-coils reader and the tag coil, where.  $L_1=0.3$  uH,  $L_2=0.058$  uH and  $L_3=0.058$  uH are respectively the self-inductances of coils 1, 2 and 3.  $r_1=0.1\Omega$ ,  $r_2=0.06\Omega$  and  $r_3=0.06\Omega$  are their internal resistances.  $C_1=0.45$  nF,  $C_2=2.32$  nF and  $C_3=2.32$  nF are the series tuning capacitors at 13.56 MHz.

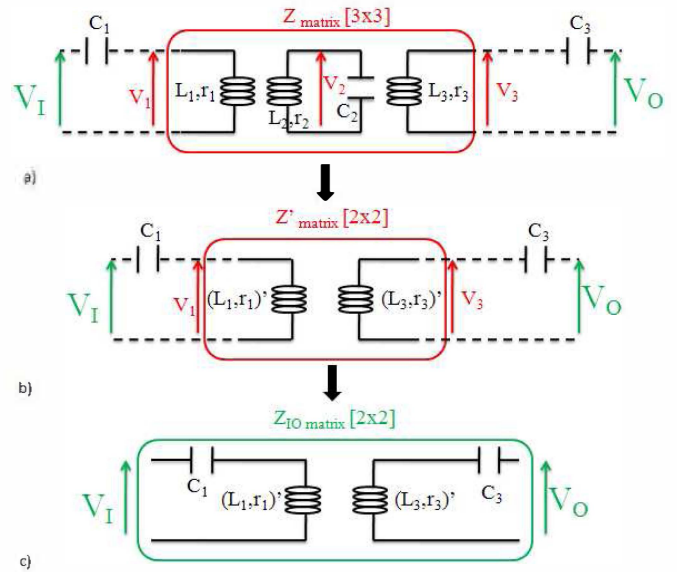

Fig. 2. Electrical equivalent models (a to c) of inductively coupled dual-coils reader/tag system

- a) initial equivalent model corresponding to matrix  $Z$
- b) simplified  $Z'$  matrix integrating the coil resonator
- c) experimental  $Z_{IO}$  matrix obtained with VNA

The voltages  $V_1$ ,  $V_2$  and  $V_3$  in the circuit satisfy the following relations (1), with  $M_{ij}=M_{ji}$  being the mutual inductances between coils 1, 2, 3, ( $1 < i, j < 3$ )

$$\begin{pmatrix} V_1 \\ V_2 \\ V_3 \end{pmatrix} = \begin{bmatrix} Z_{11} & Z_{12} & Z_{13} \\ Z_{21} & Z_{22} & Z_{23} \\ Z_{31} & Z_{32} & Z_{33} \end{bmatrix} \begin{pmatrix} I_1 \\ I_2 \\ I_3 \end{pmatrix} \quad (1)$$

$$= \begin{bmatrix} r_1 + j\omega L_1 & j\omega M_{12} & j\omega M_{13} \\ j\omega M_{21} & r_2 + j\omega L_2 & j\omega M_{23} \\ j\omega M_{31} & j\omega M_{32} & r_3 + j\omega L_3 \end{bmatrix} \begin{pmatrix} I_1 \\ I_2 \\ I_3 \end{pmatrix}$$

In simulation, each coil is fed by a lumped port, so we have matrix results with [3x3] data dimensions, but in measurements we used only the two ports of the vector network analyzer (VNA): one port for feeding the reader dual-coils structure (coil 1 with the influence of coil 2 loaded by  $C_2$ ), and the second port used for feeding the tag coil (coil 3). Consequently, we have experimental  $Z_{i0}$  matrix results with [2x2] data dimensions. Using analytical formulas, we can develop the equivalent matrix of the system (see Fig.2).

We consider the expressions of  $V_1$  and  $V_3$  mentioned in (1) with:

$$V_2 = \frac{j I_2}{C_2 \omega} \quad (2)$$

The expression of current  $I_2$  in the resonator is given by (3):

$$I_2 = \frac{j\omega M_{12}}{\alpha} I_1 + \frac{j\omega M_{23}}{\alpha} I_3 \quad (3)$$

$$\text{Where: } \alpha = \frac{j}{\omega C_2} - (j\omega L_2 + r_2)$$

The equation's system becomes:

$$V_1 = (r_1 + j\omega L_1)I_1 + j\omega M_{13}I_3 + j\omega M_{12} \left( \frac{j\omega M_{12}}{\alpha} I_1 + \frac{j\omega M_{23}}{\alpha} I_3 \right). \quad (4)$$

$$V_3 = j\omega M_{31}I_1 + (r_3 + j\omega L_3)I_3 + j\omega M_{32} \left( \frac{j\omega M_{12}}{\alpha} I_1 + \frac{j\omega M_{23}}{\alpha} I_3 \right).$$

From these equations, the  $Z'$  matrix elements are equal to:

$$\begin{aligned} Z'_{11} &= r_1 - \frac{\omega^2 M_{21}^2}{\alpha} + j\omega L_1 \\ Z'_{13} &= j\omega M_{13} - \frac{\omega^2 M_{12} M_{23}}{\alpha} \\ Z'_{31} &= j\omega M_{31} - \frac{\omega^2 M_{32} M_{12}}{\alpha} \\ Z'_{33} &= r_3 - \frac{\omega^2 M_{23}^2}{\alpha} + j\omega L_3 \end{aligned} \quad (5)$$

In the following step of the calculus, the capacitors  $C_1$  and  $C_3$  are inserted in order to find the final  $Z_{i0}$ -matrix of the entire

system: a conversion from impedance matrix to chain matrix is used.

$$\begin{pmatrix} A & B \\ C & D \end{pmatrix} = (\beta(1)) \begin{pmatrix} A' & B' \\ C' & D' \end{pmatrix} (\beta(3)) \quad (6)$$

Where  $(\beta(1))$  and  $(\beta(3))$  are the chain matrix of both capacitors  $C_1$  and  $C_3$ .

$$(\beta(i)) = \begin{pmatrix} 1 & Z C_i \\ 0 & 1 \end{pmatrix} \quad (7)$$

The final  $Z_{i0}$  matrix, considering the capacitors  $C_1$  and  $C_3$ , has the following terms:

$$\begin{aligned} Z_{ii} &= r_1 - \frac{\omega^2 M_{21}^2}{\alpha} + j\omega L_1 + Z C_1 \\ Z_{io} &= j\omega M_{13} - \frac{\omega^2 M_{12} M_{23}}{\alpha} \\ Z_{oi} &= j\omega M_{31} - \frac{\omega^2 M_{32} M_{12}}{\alpha} \\ Z_{oo} &= r_3 - \frac{\omega^2 M_{23}^2}{\alpha} + j\omega L_3 + Z C_3 \end{aligned} \quad (8)$$

When we develop, the parameters of the  $Z_{i0}$  matrix can be expressed as:

$$\begin{aligned} Z_{ii} &= j\omega \left( L_1 - \frac{1}{C_1 \omega^2} + \omega M_{21}^2 \gamma \right) + \omega^2 M_{21}^2 \delta + r_1. \\ Z_{io} &= j\omega (M_{31} + \omega M_{12} M_{23} \gamma) + \omega^2 M_{12} M_{23} \delta \\ Z_{oi} &= j\omega (M_{13} + \omega M_{32} M_{21} \gamma) + \omega^2 M_{32} M_{21} \delta \\ Z_{oo} &= j\omega \left( L_3 - \frac{1}{C_3 \omega^2} + \omega M_{31}^2 \gamma \right) + \omega^2 M_{31}^2 \delta + r_3. \end{aligned} \quad (9)$$

With

$$\begin{aligned} \gamma &= \frac{\frac{1}{C_2 \omega} - \omega L_2}{\left( \frac{1}{C_2 \omega} - \omega L_2 \right)^2 + r_2} \\ \delta &= \frac{r_2}{\left( \frac{1}{C_2 \omega} - \omega L_2 \right)^2 + r_2} \end{aligned}$$

It can be seen in equations (9) that the resonator influences all terms of the Z-matrix. In this study, we are interested in the equivalent mutual impedance parameters ( $Z_{io}$  or  $Z_{oi}$ ): the improvement of the RFID detection is done by the maximization of the module of these parameters. We use in the

following sections the terms of equivalent mutual inductance and equivalent mutual resistance for, respectively, the imaginary part divided by  $\omega$  and the real part of the equivalent impedance parameter. Their calculated expressions are given from equation 3:

$$\begin{aligned} M_{eq} &= M_{13} + \omega M_{12} M_{23} \gamma \\ R_{eq} &= \omega^2 M_{13} M_{23} \delta \end{aligned} \quad (10)$$

### III. VALIDATION OF THE CALCULATED EQUIVALENT MUTUAL IMPEDANCE

As the addition of a coil resonator on the surface of the reader is studied by calculation and simulation, we developed a specific measurement set-up to evaluate the equivalent mutual impedance improvement, in function of the tag orientation and a lateral misalignment. This measurement-setup (Fig.3) is ensuring lateral variations between the coils, using graduate millimeter scale to read accurately the position of the tag relative to the reader one.

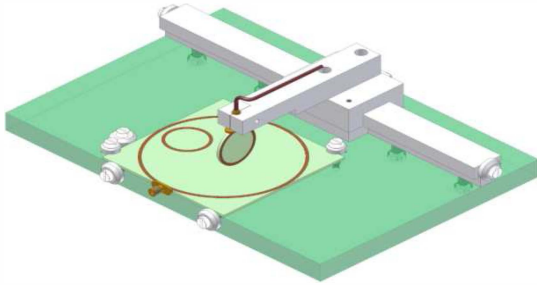

Fig. 3. Misalignment measurement-setup system fabricated

For tag misalignment ( $-50 \text{ mm} < y < 50 \text{ mm}$ ), the equivalent mutual impedance is evaluated according to the calculated expression (equation 10), and compared to the simulated and measured results in both parallel and perpendicular configuration (Fig.4).

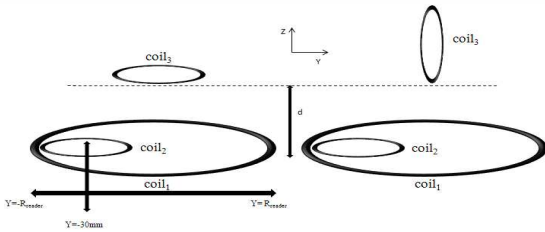

Fig. 4. Parallel (left side) and perpendicular (right side) configurations

The addition of the resonator can increase the equivalent mutual inductance and mutual resistance respectively by 10 nH (from 11nH to 21nH) and 1.1  $\Omega$  (from 0  $\Omega$  to 1.1  $\Omega$ ) above the resonator in parallel configuration (the comparison with and without resonator corresponds respectively to  $-50 \text{ mm} < y < 0 \text{ mm}$  and  $0 \text{ mm} < y < 50 \text{ mm}$  where  $y = -30 \text{ mm}$  is the center of the resonator and  $y = \pm 50 \text{ mm}$  are the edges of the reader coil) (Fig.5). However, in perpendicular configuration, the equivalent mutual inductance and the equivalent mutual resistance are improved respectively by 1.5 nH (from 3.5 nH to 4.5 nH) and 0.11  $\Omega$  (from 0  $\Omega$  to 1.1  $\Omega$ ).

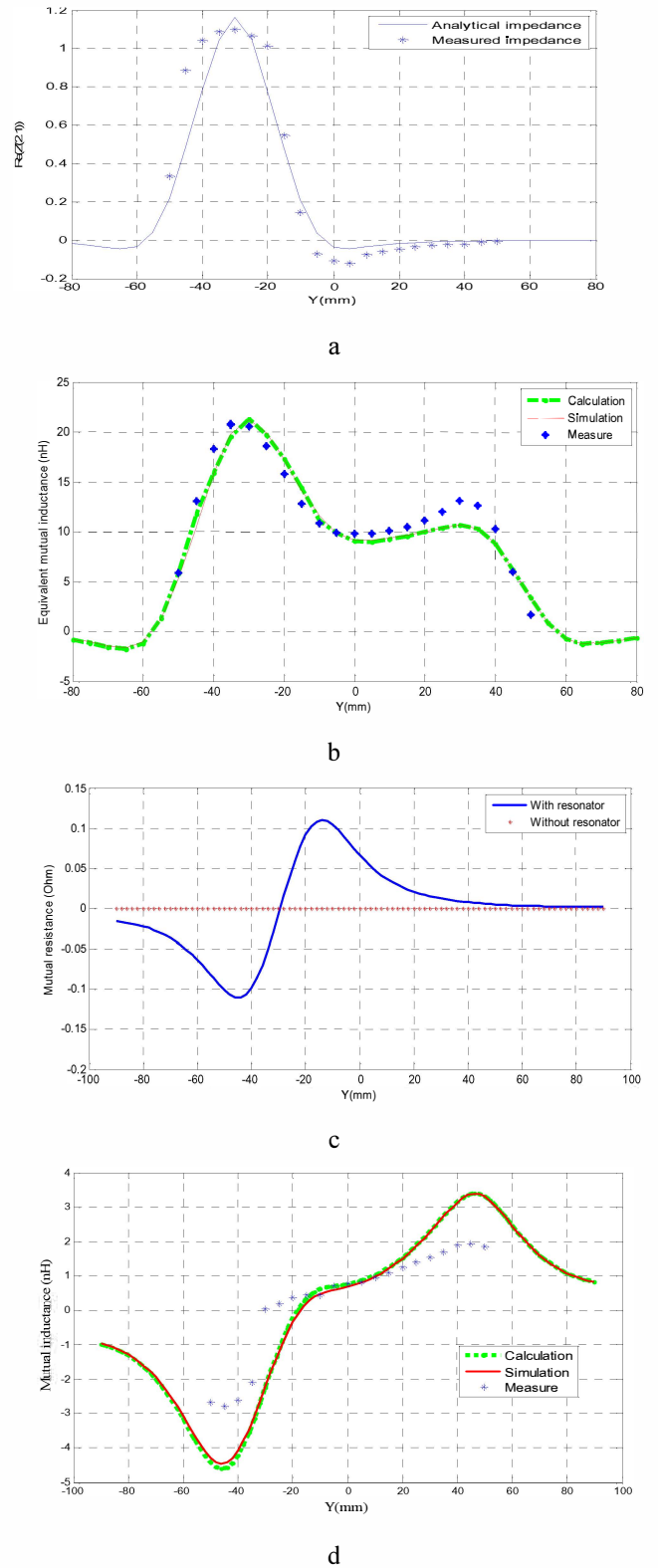

Fig.5. Equivalent mutual inductance (b, c) and equivalent mutual resistance in parallel and perpendicular configuration

The positions of the maxima of the equivalent mutual inductance and mutual resistance are always on above the resonator ( $y = -30 \text{ mm}$ ).

The calculated mutual impedance (real and imaginary parts) is confirmed by comparison to simulation and measures of the structure in both parallel and perpendicular configuration. Because of the few values of the mutual resistance in the case of perpendicular configuration, only calculation results are presented.

#### IV. CONCLUSION

Analytical calculation of the equivalent impedance matrix of complex HF RFID system is reported in this article. The principle of adding resonators in the reader coil modifies the distribution of the magnetic field, and can then increase detection volume and surface. The performances of RFID systems are evaluated by the mutual inductance, the added resonator changed this operation. New formulas of equivalent mutual impedance must be defined with the presence of resonator. These formulas are presented in this article and validated by simulations and measures of a dual-coil reader antenna. In future works, the equivalent self impedance parameters will be studied for evaluating the degradation of RFID performances by the added resonators. The degradation concerns the shift frequency in the reader and the tag coils.

#### REFERENCES

- [1] G. Eason, B. Noble, and I.N. Sneddon, "On certain integrals of S.I. Babic, F. Sirois, C. Akyel, "Validity check of mutual inductance formulas for circular filaments with lateral and angular misalignments", *Progress in Electromagnetics Research M*, Vol.8, pp.15-26, 2009.
- [2] S. Babic, C. Akyel, "New formulas for mutual inductance and axial magnetic force between magnetically coupled coils: thick circular coil of the rectangular cross-section-thin disk coil (pancake)", *IEEE Transactions on Magnetics*, Vol.49, No.2, 2013, pp.860-868,2013.
- [3] S. Hackl, C. Lansch"utzer, P. Raggam, W.L. Randeu, "A Novel Method for Determining the Mutual Inductance for 13.56MHz RFID Systems", *Communication Systems, Networks and Digital Signal Processing*, pp. 297-300, 2008
- [4] S. Hackl, C. Lansch"utzer, P. Raggam, W.L. Randeu, "A Novel Method for Determining the Mutual Inductance for 13.56MHz RFID Systems", *Communication Systems, Networks and Digital Signal Processing*, pp. 297-300, 2008
- [5] A. Diet et al. "Improving LF Reader Antenna volume of detection for RFID token tag thanks to Identical Coaxial Loops (ICLs) and in/out-of phase multiple-loops structures" *IEEE Int. Conference on RFID-Technology and Applications*, 2014 September 8-9, Tampere, Finland.
- [6] M. Benamara, M. Grzeskowiak, A.Diet, G. Lissorgues, Y.L. Bihan, "A twisted loop antenna to enhance HF RFID detection areas for different tag positioning," *Eucap 2016*, Davos
- [7] M. Grzeskowiak, A. Diet, P. S. Diao, S. Protat, C. Bourcier, Y. Le Bihan, G. Lissorgues. *Pebbles Tracking Thanks to RFID LF Multi-loops Inductively Coupled Reader*. *Progress In Electromagnetics Research*, PIER C, ISSN: 1937-8718, Vol. N°55, pp. 129-137, 2014S. Babic, C. Akyel, "New formulas for mutual inductance and axial magnetic force between magnetically coupled coils: thick circular coil of the rectangular cross-section-thin disk coil (pancake)", *IEEE Transactions on Magnetics*, Vol.49, No.2, 2013, pp.860-868,2013.