



HAL
open science

Distributed Bounded Consensus-Based Control for Multi-Agent Systems with Undirected Graphs

Andrei-Constantin Braitor, Alessio Iovine, Houria Siguerdidjane

► **To cite this version:**

Andrei-Constantin Braitor, Alessio Iovine, Houria Siguerdidjane. Distributed Bounded Consensus-Based Control for Multi-Agent Systems with Undirected Graphs. American Control Conference (ACC2023), May 2023, San Diego (California), United States. 10.23919/ACC55779.2023.10156407 . hal-04145277

HAL Id: hal-04145277

<https://centralesupelec.hal.science/hal-04145277v1>

Submitted on 29 Jun 2023

HAL is a multi-disciplinary open access archive for the deposit and dissemination of scientific research documents, whether they are published or not. The documents may come from teaching and research institutions in France or abroad, or from public or private research centers.

L'archive ouverte pluridisciplinaire **HAL**, est destinée au dépôt et à la diffusion de documents scientifiques de niveau recherche, publiés ou non, émanant des établissements d'enseignement et de recherche français ou étrangers, des laboratoires publics ou privés.

Distributed Bounded Consensus-Based Control for Multi-Agent Systems with Undirected Graphs

Andrei-Constantin Braitor, Alessio Iovine, Houria Siguerdidjane

Abstract—In this paper, we propose a distributed consensus-based control method that guarantees agent states limitation for networks of multi-agent systems with undirected communication graphs. This approach takes into account the general linear dynamic models of n identical agents and, by employing Lyapunov methods and ultimate boundedness theory, it ensures that each agent state remains within given bounds. This latter feature is particularly useful in scenarios where one must mitigate the occurrence of abnormal values being transmitted within the network, thus, maintaining a relatively safe consensus policy between agents. The developed strategy requires, at each agent node, information from their respective neighbours only, and it can be applied independently of any global information of the communication graph, hence, it is fully distributed. To highlight the developed controller capability and effectiveness, a multi-converter microgrid system with a meshed communication network has been used as a practical example. Subsequent to the asymptotic stability proof for the overall closed-loop microgrid system, the control framework has been tested in a predetermined scenario.

I. INTRODUCTION

In the preceding decades, a surge in demand for the cooperation of multiple interconnected systems took place, which sparked the initiative towards the design of distributed controllers for networked multi-agent systems. The underlying motivation stemmed from a plethora of graph-described systems ranging from the world wide web, pinning control [1], to industry fields such as vehicle platooning, power networks [2], [3] or behavioural studies, such as fish schooling, birds flocking, or insect swarming [4]–[6].

The state in which all agents in the network agree on a common initial state-dependent value is referred to as *consensus*. Consensus of multi-agent systems with general linear dynamics has always interested researchers and scholars, recent works for instance include [7]–[9]. On the control side, different static and dynamic consensus protocols are designed in [10]–[14], requiring the smallest non-zero eigenvalue of the Laplacian matrix associated with the communication graph to be known by each agent to determine the bound for the coupling weight. However, the Laplacian matrix depends on the entire communication graph and, hence, is global information. That would make the controller centralised, with the network of agents essentially

The authors are with Laboratoire des Signaux et Systèmes (L2S), CentraleSupélec, CNRS, Université Paris-Saclay, Gif-sur-Yvette, France (emails: {andrei.braitor, alessio.iovine, houria.siguerdidjane}@centralesupelec.fr). This project has received funding from the Agence Nationale de la Recherche (ANR) under Grant ESTHER ANR-22-CE05-0016.

This project has received funding from the Agence Nationale de la Recherche (ANR) under Grant ESTHER ANR-22-CE05-0016.

becoming a single complex system. Thus, the complexity of the centralised controller increases when the network scales up due to the need to compute the eigenvalue. Moreover, in most cases a centralised controller might fail to observe the full state information due to communication constraints among agents. Similarly, it might be subjected to failure when network topology changes, as in plug and play scenarios. In other words, the consensus protocols in [10]–[14] cannot be computed and implemented by each agent in a fully distributed fashion, that is using only local available information or shared information from its own neighbours.

Thence, given the spatial distribution of the agents and limited sensing capability of sensors, implementable consensus protocols for multi-agent systems should be distributed, depending on the local state or output information of each agent and its neighbours only. To address these shortcomings, several improved distributed consensus protocols have been proposed in [15]–[17], which are based on the relative states combined with adaptive laws for adjusting the coupling weights between neighbours. Most of these methods are inspired by the edge-based adaptive strategy for the synchronization of complex networks as in [18]. The downside of these adaptive consensus approaches that introduce adaptive coupling gains is that these gains could become considerably large. A possible solution to address this issue would be to implement an adaptive consensus protocol with decaying gains as proposed in [19]. However, although a decaying gain can tackle the unbounded coupling gain issue, it cannot guarantee agent state boundedness. And, state boundedness has recently become quite a crucial property to have in modern complex systems, as for example in power networks where the need for protection through control has never been a more sought-after feature [20]–[22].

On the downside, distributive-based approaches suffer from high-control effort and, sometimes, weak robustness. To this end, a number of research works have explored distributed structures that seek a balance between system performance and the coordination efforts, which can be quantified either in communication or computational demands [23]. This two-fold goal has led to control structures incorporating low-degree consensus networks, hence, avoiding the need for full information sharing. As explained in [24], from a static viewpoint, the problem is similar to that of system partitioning, which searches for suitable decompositions of the global system into subsystems and assigns variables to different control agents

So far, however, a distributed consensus-based controller that guarantees an upper bound for every agent state, to the

best of our knowledge, has never been proposed in this form. The contribution of this paper can be briefly summarised as follows: i) the proposed method addresses the issue of large and unbounded coupling gains, by having a bounded term acting as a coupling gain; ii) the design of control framework can also guarantee bounded agent states, by virtue of Lyapunov methods and ultimate boundedness theory; iii) it is fully distributed and independent of the other agent parameters or states; iv) it can seamlessly incorporate agent clustering and/or network partition.

II. PRELIMINARIES AND MOTIVATION

Let $\mathbf{0}_n$, $\mathbf{1}_n$, and $\mathbf{0}_{n \times n}$, $\mathbf{1}_{n \times n}$ denote the n -dimensional vector and $n \times n$ dimensional matrix, respectively, of zero and unit entries, respectively, and let I_n denote the identity matrix. For an n -tuple (v_1, \dots, v_n) , let $v \in \mathbb{R}^n$ be the associated vector. Given the ordered index set \mathcal{I} of cardinality $|\mathcal{I}|$ and a one-dimensional array $\{x_i\}_{i \in \mathcal{I}}$, one defines $[x] = \text{diag}(\{x_i\}_{i \in \mathcal{I}}) \in \mathbb{R}^{|\mathcal{I}| \times |\mathcal{I}|}$ to be the associated diagonal matrix. Its corresponding transpose matrix is denoted as $[x]'$. Define the vector-valued function $\text{abs}(v) = [|v_1| \dots |v_n|]'$ as the vector function that has all vector entries as scalar absolute values.

Consider a group of n identical agents with general linear dynamics. The dynamics of the i -th agent would have the following LTI dynamics written in matrix form, with $x = [x_1 \dots x_n]'$, and $u = [u_1 \dots u_m]'$

$$\dot{x} = Ax + Bu, \quad (1)$$

where $x \in \mathbb{R}^n$ represents the state vector, $u \in \mathbb{R}^m$ is the control input vector, while $A \in \mathbb{R}^{n \times n}$ and $B \in \mathbb{R}^{n \times m}$ are constant matrices of compatible dimensions.

Consider the following assumptions and preliminaries necessary for the subsequent theoretical developments.

Assumption 1. *One assumes the matrix pair (A, B) is controllable.*

Since system (1) is controllable according to the above assumption, then for every $\mu > 0$, there exists a state feedback controller $u = -Kx$, with $K \in \mathbb{R}^{m \times n}$ a gain matrix, that places all eigenvalues of the closed-loop system $\dot{x} = (A - BK)x$ on the complex semiplane $\mathcal{R}(\lambda) \leq -\mu$.

Graph theory has been widely used to describe the communication topology among the multi-agent networked systems. Consider the undirected, connected, and weighted graph $\mathcal{G} = (\mathcal{V}, \mathcal{E}, W)$ represented as a set of vertices, or agents, $\mathcal{V} = \{i | i \in \mathcal{I}\}$, connected by a set of edges, or communication links, $\mathcal{E} \subset \mathcal{V} \times \mathcal{V}$, and induced by a symmetric, irreducible, and non-negative matrix $W \in \mathbb{R}^{n \times n}$, namely the adjacency matrix. The elements of W represent the weights, where $w_{ij} > 0$ if the edge $(\nu_j, \nu_i) \in \mathcal{E}$, otherwise, $w_{i,j} = 0$. The Laplacian matrix $\mathcal{L} \in \mathbb{R}^{n \times n}$ is defined as $\mathcal{L} = [W\mathbf{1}_n] - W$, while its eigenvalues determine the global dynamics.

A variety of graph-based static and dynamic consensus approaches have been proposed to guarantee agent consensus with dynamics given by equation (1). A static consensus

based on the relative states between neighbouring agents would look as proposed in [13],

$$u_i = cK \sum_{i=1}^n w_{ij} (x_i - x_j), \quad i \in \mathcal{I} \quad (2)$$

with $c > 0$ being the coupling weight among neighbouring agents, K is the feedback term, and w_{ij} is (i, j) -th entry of the adjacency matrix W associated to \mathcal{G} . When the neighbouring agents i and j become equal, they are known as reaching *synchronisation* as defined below for the entire network.

Definition 1. *Network system (1)-(2) is said to achieve asymptotic synchronisation if and only if*

$$\lim_{t \rightarrow \infty} (x_i(t) - x_j(t)) = 0, \quad i, j: (\nu_i, \nu_j) \in \mathcal{E}. \quad (3)$$

Note that asymptotic synchronisation as defined above is the most intuitive case of synchronisation, and it corresponds to consensus among agents $x_i = x_j$, with j being a neighbour of i , i.e. $j \in \mathcal{N}_i$. There also exist other forms of synchronisation, for instance, *lag synchronisation* as defined in [25].

Lemma 1 ([13]). *For \mathcal{G} connected, the n agents reach consensus with u defined as in (2), with $K = -B'P^{-1}$ and the coupling weight $c \geq \frac{1}{\lambda_2}$, where λ_2 is the smallest non-zero eigenvalue of the Laplacian \mathcal{L} and $P \succ 0$ is a solution to the following linear matrix inequality*

$$AP + PA' - 2BB' < 0. \quad (4)$$

The coupling weight c should be greater than the inverse of the second smallest eigenvalue of \mathcal{L} to reach consensus. Similarly, the control design in [14] depends on λ_2 also. However, λ_2 is global information since it depends on the entire network configuration. Therefore, the controller cannot be implemented in a distributed fashion at each agent node.

Note that in equation (4), one does not formally imply BB' being positive-definite. Nevertheless, the controllability of the pair (A, B) from Assumption 1 suffices to establish that P is positive-definite, even if BB' is not, a fact also pointed out in [26, Ch.12]. To make matters clear and mathematically rigorous, one makes a second assumption.

Assumption 2. *Matrix $B \in \mathbb{R}^{n \times m}$ is full row rank, i.e. $\text{rank}(B) = n$.*

This guarantees that symmetric matrix BB' is full rank. Moreover, matrix BB' is positive-definite, thus invertible. An important remark here, however, is that in line with Assumption 2, matrix B dimensions should satisfy $n \leq m$.

To avoid the limitation stated in Lemma 1, adaptive approaches have been developed in [19], where c takes a dynamic form

$$c = \sum_{j=1}^N w_{ij} (x_j - x_i) \Gamma(x_j - x_i) + \sum_{j=1}^N w_{ij} (c_j - i_i) - l(c_i - \kappa_i) \quad (5)$$

where $l > 0$ and $\kappa_i \geq 0$ are constants, the latter is estimated by the i -th agent, while Γ is the adaptation game term. However, although the adaptive gain removes the issue of large

or unbounded coupling gain as these adaptive gains decay to virtually zero, it cannot ensure agent state boundedness.

In turn, we propose, in the following section, a bounded consensus approach that is fully distributed and additionally attains an upper bound for the agent states.

III. BOUNDED CONSENSUS-BASED CONTROL

In this section, a distributed bounded consensus-based controller is designed that achieves network consensus, and additionally secures an upper bound for the agent states.

A. Controller design and analysis

Consider the control input vector taking the following matrix form, with $\sigma = [\sigma_1 \dots \sigma_n]'$,

$$u = -Kx + \frac{1}{2}B'\sigma \quad (6)$$

where one selects gain matrix $K = B'Q$, with $Q = \text{diag}\{q_i\} \in \mathbb{R}^{n \times n}$ being a positive-definite diagonal matrix. The control state σ_i takes the following dynamic form for each i -th agent,

$$\dot{\sigma}_i = \left(1 - \frac{(\sigma_i - q_i\bar{x}_i)^2}{(q_i\bar{x}_i)^2}\right) \sum_{j \in \mathcal{N}_i} (x_j - x_i) \quad (7)$$

with the purpose of maintaining σ_i within given bounds, where \bar{x}_i is a positive constant. To explain this in more depth, one proceeds to investigate the nonlinear dynamics of equation (7).

Consider the following continuously-differentiable function

$$W = \frac{\sigma_i^2}{2(q_i\bar{x}_i)^2}. \quad (8)$$

Then, by calculating its time derivative and using the controller expression in (7), it yields

$$\begin{aligned} \dot{W}_i &= \frac{\sigma_i}{(q_i\bar{x}_i)^2} \dot{\sigma}_i \\ &= \frac{\sigma_i}{(q_i\bar{x}_i)^2} \left(1 - \frac{(\sigma_i - q_i\bar{x}_i)^2}{(q_i\bar{x}_i)^2}\right) \sum_{j \in \mathcal{N}_i} (x_j - x_i) \end{aligned} \quad (9)$$

From equation (9), one can notice that except at the synchronisation when consensus is reached (i.e. $x_i = x_j$) or at the origin where $\sigma_i = 0$, \dot{W}_i becomes zero at the roots of the parabola $p(\sigma_i)$ as it can be seen in Fig. 1. This indicates that if the initial condition of the controller state, σ_{i0} , is selected in the set

$$W_{i0} = \left\{ \sigma_i \in \mathbb{R} : p(\sigma_i) = 1 - \frac{(\sigma_i - q_i\bar{x}_i)^2}{(q_i\bar{x}_i)^2} > 0 \right\} \quad (10)$$

then, intuitively from equation (9), it becomes clear that \dot{W}_i will eventually become null as it travels on the parabola $p(\sigma_i) > 0$, that is

$$\dot{W}_i(t) \rightarrow 0, \forall t \geq 0. \quad (11)$$

This leads to the result that σ_i will start and remain in the set W_{i0} for all $t \geq 0$. In other words, the set W_{i0} is a positive invariant set. Hence, a choice for the initial condition

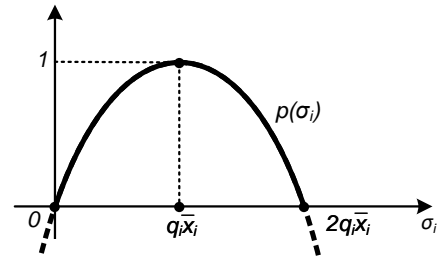

Fig. 1. Graphical representation of the $p(\sigma_i)$ parabola

σ_i could be anywhere within $0 \leq \sigma_i \leq 2q_i\bar{x}_i$. To remark here that keeping the controller states on well-defined curves has been encountered in several bounded control approaches. For more details on the motivation behind the proposed controller, the reader is referred to [27], [28].

Hence, by considering a typical initial condition of the integral state σ_i , i.e. $\sigma_i(0) = q_i\bar{x}_i$, then the controller state remains following the equilibria of equation (7), within the interval $\sigma_i(t) \in [0, 2q_i\bar{x}_i]$, for all $t \geq 0$.

One has to remark that the control variable \dot{W}_i becomes zero when i) $\sum_{j \in \mathcal{N}_i} (x_j - x_i) = 0$ which ensures accurate consensus among all network agents, or ii) $\sigma_i = 0$ and $\sigma_i = 2q_i\bar{x}_i$ corresponding to agent state limitation as it shall be explained in the following subsection.

B. State boundedness

When substituting the control input (6) into the open-loop dynamics (1), one obtains the closed-loop system

$$\dot{x} = Ax - BB'Qx + \frac{1}{2}BB'\sigma \quad (12)$$

Proposition 1. *The solution $x_i(t)$ of system (12) with the initial condition $x_i(0) \leq \bar{x}_i$ is uniformly ultimately bounded, i.e. $|x_i(t)| \leq \bar{x}_i$, at all times $t \geq 0$.*

Proof. Now consider the following Lyapunov function candidate:

$$V = \frac{1}{2}x'x. \quad (13)$$

By taking its time derivative, it yields $\dot{V} = x'\dot{x}$ as shown in the expansion below

$$\begin{aligned} \dot{V} &= x' \left(Ax - BB'Qx + \frac{1}{2}BB'\sigma \right) \\ &\leq x' (Ax - BB'Q \text{abs}(x) + BB'Q\bar{x}). \end{aligned} \quad (14)$$

As in equation (4) in Lemma 1 regarding consensus reaching, let matrix A be Hurwitz. Since B is a full row rank matrix, by virtue of Assumption 2, then the symmetric matrix $(BB')^{-1}$ exists and is positive-definite. Then, by diagonalisation according to the lemmas in [29], matrix $BB'Q$ is positive stable, that is $BB'Q$ has only positive eigenvalues. Then, one has

$$\dot{V} \leq x'Ax, \forall \text{abs}(x) \geq BB'Q(BB'Q)^{-1}\bar{x} \geq \bar{x} \quad (15)$$

which guarantees, for each agent i , the desired state limitation, i.e. $|x_i| \leq \bar{x}_i$. The proof is complete. \square

Notice that maintaining the agents states within bounds is accomplished independently from the consensus function $\sum_{j \in \mathcal{N}_i} (x_j - x_i)$ that has to eventually tend towards zero. Given some agents reach their limit, the others will still attempt to keep consensus policy accurate between them.

Remark 1 (Implications on network scalability). *Network scalability is intrinsically connected to the algebraic connectivity λ_2 of the communication induced graph \mathcal{L} . And connectivity scales unfavourably with network size which points to a fundamental limitation in the scalability of consensus networks. However, this limitation applies only to consensus networks with leaders, or when some network grounding would occur (resulting in leader-follower consensus) [30].*

IV. A DC MICROGRID EXAMPLE

To test and highlight the capabilities of the proposed control approach, one considers a DC microgrid application. Notice in Fig. 2, the multi-converter based DC network with n converter nodes connected through RL lines to a common DC bus, represented by the resistance R . Each converter node shares information with its respective neighbours via a meshed connected communication network.

By applying Kirchhoff's Laws, the dynamics of the current flowing from each node i to the DC bus can be expressed as

$$L_i \frac{di_i}{dt} = E_i - R_i i_i - R \sum_{i=1}^n i_i, \quad (16)$$

where E_i and i_i represent the converter-node voltage and line current, respectively, the former being also the control input. One can rewrite equation (16) in matrix form, yielding

$$L \frac{di}{dt} = E - (R_L + R \mathbf{1}_{n \times n}) i, \quad (17)$$

with line inductance and resistance matrices $L = \text{diag}\{L_i\}$ and $R_L = \text{diag}\{R_i\}$, and input and state vectors $E = [E_1 \dots E_n]'$ and $i = [i_1 \dots i_n]'$, respectively.

When the control input vector E takes the form

$$E = -K i + \frac{1}{2} L^{-1} \sigma, \quad (18)$$

one obtains the following closed-loop system

$$L \dot{i} = -K i + \frac{1}{2} L^{-1} \sigma - (R_L + R \mathbf{1}_{n \times n}) i. \quad (19)$$

The control state σ incorporates the bounded consensus approach and takes the following nonlinear dynamic form

$$\dot{\sigma} = \left(I_n - ([\sigma] - g I_{max})^2 (g I_{max})^{-2} \right) \mathcal{L} m i. \quad (20)$$

Matrix $m = \text{diag}\{m_i\} > 0$ introduces different gains to allow the implementation of a clustering policy among converter nodes, while maintaining consensus between all nodes in the network. The main task is to ensure current consensus among all nodes. given the line currents at each node i , do not exceed a specific imposed limit, i.e., $i_i \leq I_{max,i}$.

The stability of the closed-loop system (19)-(20) will be analysed in the sequel.

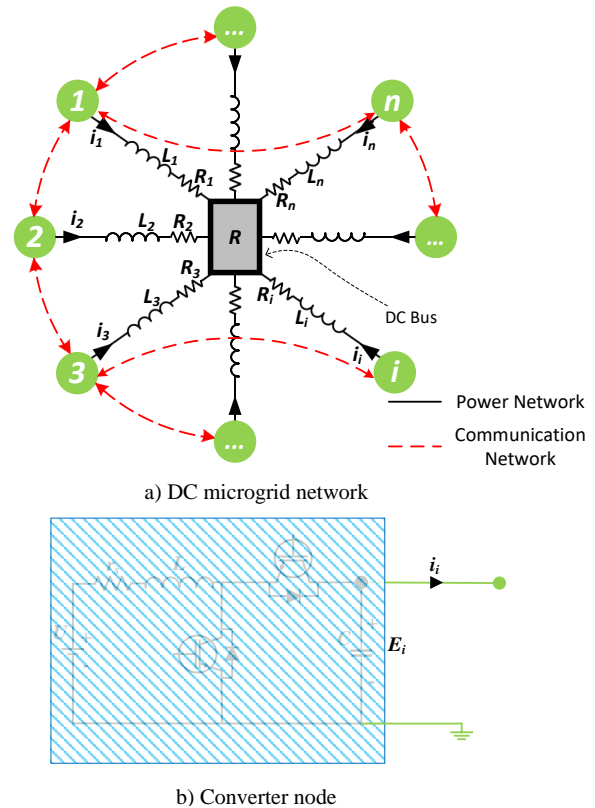

Fig. 2. Multi-converter based DC microgrid incorporating a meshed communication network

A. Closed-loop stability analysis

One can trivially observe by checking the equilibria of σ , that it has two equilibrium points, at $\mathbf{0}_n$ and $2g I_{max} \mathbf{1}_n$, with the latter being of interest for stability investigation.

In this subsection, the local closed-loop stability is investigated around the equilibrium point denoted (i_e, σ_e) . Consider the following proposition that guarantees closed-loop stability.

Proposition 2. *Closed-loop system (19)-(20) is locally asymptotically stable.*

Proof. The corresponding Jacobian matrix of the closed-loop system (19)-(20) will look as displayed at the top of the next page.

By writing the standard eigenvalue problem (SEP) for (21), one has $Jv = \lambda v$, with λ being an eigenvalue, and v the corresponding eigenvector. Since the Jacobian matrix can be written as a matrix multiplication as expressed below

$$J = \underbrace{\begin{bmatrix} -L^{-1} & \mathbf{0}_{n \times n} \\ \mathbf{0}_{n \times n} & -2([\sigma_e] - g I_{max}) (g I_{max})^{-2} \end{bmatrix}}_{X_1} \times \underbrace{\begin{bmatrix} K + R_L + R \mathbf{1}_{n \times n} & \mathbf{0}_{n \times n} \\ \mathbf{0}_{n \times n} & \mathcal{L} \end{bmatrix}}_{X_2} \underbrace{\begin{bmatrix} I_n & \mathbf{0}_{n \times n} \\ \mathbf{0}_{n \times n} & m [i_e] \end{bmatrix}}_{\bar{Q}}, \quad (22)$$

the SEP then becomes

$$X_1 X_2 \bar{Q} v = \lambda v. \quad (23)$$

$$J = \begin{bmatrix} -L^{-1}(K + R_L + R\mathbf{1}_{n \times n}) & \frac{1}{2}L^{-2} \\ \mathbf{0}_{n \times n} & -2([\sigma_e] - gI_{max})(gI_{max})^{-2} \mathcal{L}m[i_e] \end{bmatrix} \quad (21)$$

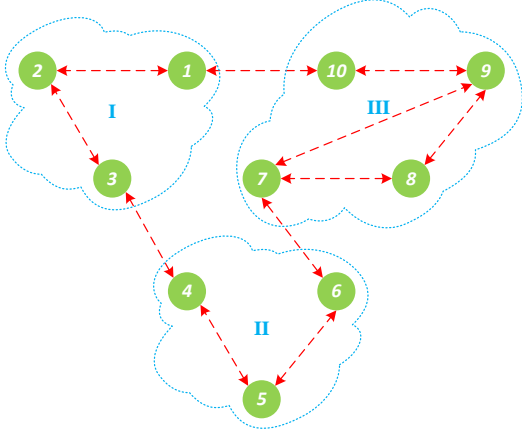

Fig. 3. DC network considered for simulation testing

Given matrix $\bar{Q} \succ 0$, let $y = \bar{Q}v$ resulting in

$$X_1 X_2 y = \lambda \bar{Q}^{-1} y. \quad (24)$$

The SEP becomes a generalised eigenvalue problem (GEP). Matrix X_2 is positive semidefinite with kernel spanned by $[\mathbf{0}'_n \mathbf{1}'_n]'$ corresponding to the asymptotic synchronisation (as in Definition 1) or the states reaching consensus, while matrix X_1 is positive definite with kernel spanned by $\mathbf{0}_{2n}$. Similarly to the proof of [31, Th.2], by applying the Courant-Fischer Theorem to the eigenvalue problem, for asymptotic synchronisation, all eigenvalues of matrix J are real and negative since $Im(\mathcal{L}) = \mathbf{1}_n^\perp$, and $Im(X_1) \cap ker(X_2) = \mathbf{0}_{2n}$, which means that $X_2 y$ is never in the kernel of X_1 .

Therefore, it is clear that $ker(J) = ker(X_2)$. Since the image of matrix X_1 excludes $span([\mathbf{0}'_n \mathbf{1}'_n]')$, it follows that Jy is the null vector if and only if $y \in span([\mathbf{0}'_n \mathbf{1}'_n]')$ that essentially corresponds to the asymptotic synchronisation. Thus, matrix J is Hurwitz. The system is locally asymptotically stable. The proof is complete. \square

B. Simulation results

A 10-node network has been subjected to numerical testing, with a meshed configuration as depicted in Fig. 3, with

System and control parameters	Values
$L_{1...10}$ [mH]	0.25 0.23 0.22 0.17 0.2 0.21 0.24 0.24 0.25 0.23
$R_{1...10}$ [Ω]	1.05 1.1 0.7 0.85 0.9 1.2 0.75 0.6 0.75 0.5
$I_{max,1...10}$ [A]	3.8 3.8 3.8 3.5 3.5 3.5 0.84 0.84 0.84 0.84
$m_{1...10}$	21 21 21 10.5 10.5 10.5 7 7 7 7
$g_{1...10}$	50 50 50 50 50 50 60 60 60 60

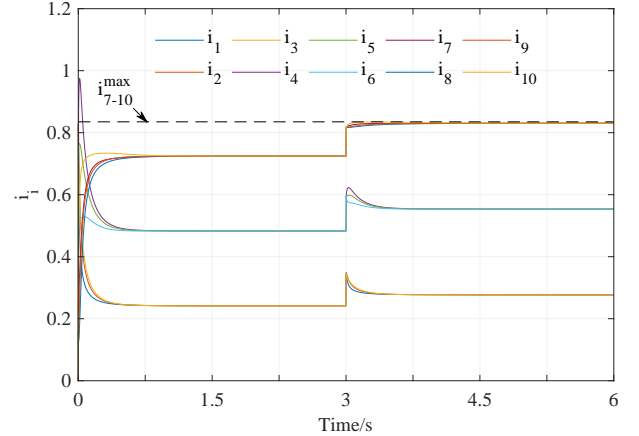

a) line currents i_i

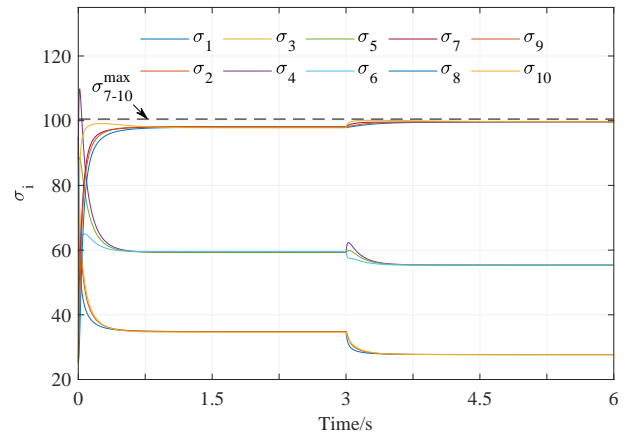

b) control states σ_i

Fig. 4. Dynamic response of the system and control states

the line currents being described by equation (16). Note that the nodes have been clustered in three zones with the end goal of guaranteeing different consensus with the zone within their zone, than with the nodes in the rest of the network. At each converter node, the bounded consensus approach has been implemented in a distributed manner.

The simulation scenario runs for 6 s and the main tasks for each agent is to show the controller operability, i.e. i) consensus among all network agents, and ii) state boundedness for each agent state. The results are displayed in Fig. 4.

At $t = 0$ s, the controllers start and after a 1 s settling time, consensus is achieved among all agents. Note that agents achieve equal consensus with their neighbours within their zone and a 1 : 2 : 3 consensus with their respective neighbours from zones other than their own.

After 3 s, the load power demand at the DC bus changes causing the line currents to change as a response. The upper limit is hit in zone III, the currents are successfully limited while in the other zones the currents readjust to maintain the consensus in place.

Remark 2. One could choose to keep the consensus only among the nodes that have not reached their limit. That could be implemented in a practical manner by simply removing from the consensus the states that have reached the limit. However, for the purpose of this demonstration, no such thing has been put in place.

On the whole, the present approach manages to ensure no violation occurs and keep the upper bound in place, i.e. $i_i \leq i_i^{max}$, $\forall t \geq 0$, even during transients.

V. CONCLUSIONS

In this paper, a distributed bounded consensus-based control method has been proposed for linear multi-agent systems with undirected communication network induced graphs. By using Lyapunov methods and ultimate boundedness theory, an upper bound for each agent state can be analytically guaranteed independently of the system states or parameters. To verify the theoretical findings and verify the controllers performance, a DC microgrid with meshed communication network has been considered as a testing example. The closed-loop stability of the DC system has been proven around an equilibrium point. Lastly, the system has been subjected to a simulation scenario, where it is clear that the proposed method ensures accurate consensus among converter-node currents, while keeping a fixed pre-set limit.

REFERENCES

- [1] T. Chen, X. Liu, and W. Lu, "Pinning complex networks by a single controller," *IEEE Transactions on Circuits and Systems I: Regular Papers*, vol. 54, no. 6, pp. 1317–1326, 2007.
- [2] S. Sheikholeslam and C. Desoer, "Control of interconnected nonlinear dynamical systems: the platoon problem," *IEEE Transactions on Automatic Control*, vol. 37, no. 6, pp. 806–810, 1992.
- [3] M. Andreasson, E. Tegling, H. Sandberg, and K. H. Johansson, "Performance and scalability of voltage controllers in multi-terminal hvdc networks," in *2017 American Control Conference (ACC)*, 2017, pp. 3029–3034.
- [4] P. Zhang, Z. Wu, H. Dong, M. Tan, and J. Yu, "Reaction-wheel-based roll stabilization for a robotic fish using neural network sliding mode control," *IEEE/ASME Transactions on Mechatronics*, vol. 25, no. 4, pp. 1904–1911, 2020.
- [5] P. DeLellis, M. di Bernardo, T. E. Goroehowski, and G. Russo, "Synchronization and control of complex networks via contraction, adaptation and evolution," *IEEE Circuits and Systems Magazine*, vol. 10, no. 3, pp. 64–82, 2010.
- [6] M. A. Haque, M. Egerstedt, and C. F. Martin, "First-order, networked control models of swarming silkworm moths," in *2008 American Control Conference*, 2008, pp. 3798–3803.
- [7] X. Bu, P. Zhu, Z. Hou, and J. Liang, "Finite-time consensus for linear multi-agent systems using data-driven terminal ilc," *IEEE Transactions on Circuits and Systems II: Express Briefs*, vol. 67, no. 10, pp. 2029–2033, 2020.
- [8] L. Bingqiang, L. Tianyi, Z. Yiyun, and L. Shuaishuai, "Open-loop and closed-loop da-type iterative learning control for fractional-order linear multi-agent systems with state-delays," *Journal of Systems Engineering and Electronics*, vol. 32, no. 1, pp. 197–208, 2021.
- [9] M. Axelson-Fisk and S. Knorn, "A graph theoretic approach to ensure a scalable performance measure in multi-agent systems with mimo agents," *IFAC-PapersOnLine*, vol. 55, no. 13, pp. 103–108, 2022, 9th IFAC Conference on Networked Systems NECSYS 2022.
- [10] S. E. Tuna, "Conditions for synchronizability in arrays of coupled linear systems," *IEEE Transactions on Automatic Control*, vol. 54, no. 10, pp. 2416–2420, 2009.
- [11] J. H. Seo, H. Shim, and J. Back, "Consensus of high-order linear systems using dynamic output feedback compensator: Low gain approach," *Automatica*, vol. 45, no. 11, pp. 2659–2664, 2009.
- [12] C.-Q. Ma and J.-F. Zhang, "Necessary and sufficient conditions for consensusability of linear multi-agent systems," *IEEE Transactions on Automatic Control*, vol. 55, no. 5, pp. 1263–1268, 2010.
- [13] Z. Li, Z. Duan, G. Chen, and L. Huang, "Consensus of multiagent systems and synchronization of complex networks: A unified viewpoint," *IEEE Transactions on Circuits and Systems I: Regular Papers*, vol. 57, no. 1, pp. 213–224, 2010.
- [14] H. Zhang, F. L. Lewis, and A. Das, "Optimal design for synchronization of cooperative systems: State feedback, observer and output feedback," *IEEE Transactions on Automatic Control*, vol. 56, no. 8, pp. 1948–1952, 2011.
- [15] Z. Li, G. Wen, Z. Duan, and W. Ren, "Designing fully distributed consensus protocols for linear multi-agent systems with directed graphs," *IEEE Transactions on Automatic Control*, vol. 60, no. 4, pp. 1152–1157, 2015.
- [16] H. Rezaee and F. Abdollahi, "Adaptive consensus control of nonlinear multiagent systems with unknown control directions under stochastic topologies," *IEEE Transactions on Neural Networks and Learning Systems*, vol. 29, no. 8, pp. 3538–3547, 2018.
- [17] X. Jin, S. Lü, and J. Yu, "Adaptive nn-based consensus for a class of nonlinear multiagent systems with actuator faults and faulty networks," *IEEE Transactions on Neural Networks and Learning Systems*, vol. 33, no. 8, pp. 3474–3486, 2022.
- [18] Y. Zhao, G. Wen, Z. Duan, and G. Chen, "Adaptive consensus for multiple nonidentical matching nonlinear systems: An edge-based framework," *IEEE Transactions on Circuits and Systems II: Express Briefs*, vol. 62, no. 1, pp. 85–89, 2015.
- [19] Štefan Knotek, K. Hengster-Movric, and M. Šebek, "Distributed adaptive consensus protocol with decaying gains on directed graphs," *IFAC-PapersOnLine*, vol. 49, no. 22, pp. 355–360, 2016, 6th IFAC Workshop on Distributed Estimation and Control in Networked Systems NECSYS 2016.
- [20] A. C. Braitor, G. C. Konstantopoulos, and V. Kadiramanathan, "Current-limiting droop control design and stability analysis for parallel boost converters in DC microgrids," *IEEE Transactions on Control Systems Technology*, pp. 1–10, 2020.
- [21] A.-C. Braitor, G. C. Konstantopoulos, and V. Kadiramanathan, "Enhanced primary droop controller for meshed dc micro-grids with overvoltage protection," in *2021 29th Mediterranean Conference on Control and Automation (MED)*, 2021, pp. 368–373.
- [22] A.-C. Braitor, G. C. Konstantopoulos, and V. Kadiramanathan, "Novel droop control design for overvoltage protection of dc microgrids with a constant power load," in *2020 28th Mediterranean Conference on Control and Automation (MED)*, 2020, pp. 875–880.
- [23] F. Dörfler, M. R. Jovanović, M. Chertkov, and F. Bullo, "Sparsity-promoting optimal wide-area control of power networks," *IEEE Transactions on Power Systems*, vol. 29, no. 5, pp. 2281–2291, 2014.
- [24] P. Chanfreut, J. M. Maestre, and E. F. Camacho, "A survey on clustering methods for distributed and networked control systems," *Annual Reviews in Control*, vol. 52, pp. 75–90, 2021.
- [25] S. Boccaletti and D. Valladares, "Characterization of intermittent lag synchronization," *Physical review. E, Statistical physics, plasmas, fluids, and related interdisciplinary topics*, vol. 62, pp. 7497–500, 12 2000.
- [26] J. P. Hespanha, *Linear Systems Theory*. Princeton, New Jersey: Princeton Press, Feb. 2018, ISBN13: 9780691179575.
- [27] G. C. Konstantopoulos, Q. C. Zhong, B. Ren, and M. Krstic, "Bounded integral control of input-to-state practically stable nonlinear systems to guarantee closed-loop stability," *IEEE Transactions on Automatic Control*, vol. 61, no. 12, pp. 4196–4202, Dec 2016.
- [28] G. C. Konstantopoulos, "Enhanced bounded integral control of input-to-state stable nonlinear systems," *IFAC-PapersOnLine*, vol. 50, no. 1, pp. 8151–8156, 2017, 20th IFAC World Congress.
- [29] A.-C. Braitor, G. Konstantopoulos, and V. Kadiramanathan, "Admittance matrix computation and stability analysis of droop controlled DC micro-grids with CPL," *IFAC-PapersOnLine*, vol. 53, no. 2, pp. 13 525–13 530, 2020, 21th IFAC World Congress.
- [30] E. Tegling, R. H. Middleton, and M. M. Seron, "Scalability and fragility in bounded-degree consensus networks," *IFAC-PapersOnLine*, vol. 52, no. 20, pp. 85–90, 2019, 8th IFAC Workshop on Distributed Estimation and Control in Networked Systems NECSYS 2019.
- [31] A.-C. Braitor, G. Konstantopoulos, and V. Kadiramanathan, "Stability analysis of dc micro-grids with cpls under novel decentralized primary and distributed secondary control," *Automatica*, vol. 139, p. 110187, 2022.